



City of Phoenix

ENTERPRISE INFORMATION TECHNOLOGY STANDARD

Domain: <i>INF Architecture Series</i>		Number: <i>200.215</i>	Standard Title: <i>Telecommunications Cabling Systems</i>				
Authorizing AR		AR 1.73					
Regulatory Standards		Refer to Section V. Related Policies, Standards, and Procedures					
Original Approval		mm/dd/yyyy					
Number	Version	Pages	Effective Date	Last Review	Next Review	Approved by	Distribution
200.215	3.0	50	2/2/2023	2/2/2023	2/2/2024	T. Magrini	

I. PURPOSE AND APPLICABILITY

This standard establishes the requirements for deploying and managing the physical layer inside and Outside the Plant of the City’s telecommunications infrastructure. The goal is to ensure the City’s telecommunications infrastructure meets customer needs, industry safety standards, technical and performance specifications, and warranty requirements.

Approval authority of a telecommunications infrastructure design, inspection, and acceptance rests solely with Information Technology Services (ITS). ITS will design telecommunications solutions that are technically appropriate to meet a department’s present operational and business needs and those of the foreseeable future. The department must develop the design for specific facilities or functional area staff in partnership with ITS as part of the normal facilities design, review, and approval process.

NOTE: ITS is responsible for ensuring that all materials' installation shall be completed in a good and workmanlike manner and with the highest standards of the telecommunications industry. All work and materials must be in full accord with the requirements of the Arizona administrative code, the state fire marshal, the division of industrial safety, the National Electric Code, and other applicable city and state laws or regulations. Nothing in the specifications shall be construed to permit work not conforming to these codes and orders.

NOTE: Certain sections of this document will indicate requirements specific to the City’s Aviation facilities.

II. BACKGROUND

A structured cabling system is the complete collective configuration of cabling and associated hardware at a given site installed to provide a comprehensive telecommunications infrastructure. This infrastructure is intended to serve a wide range of usage (i.e., telephone service, wired and wireless computer networks, Closed Circuit Television (CCTV), building automation, telecommunications rooms, etc.) and is not device dependent.

Domain: <i>INF Architecture</i>	Number: <i>200.215</i>	Standard Title: <i>Telecommunications Cabling Systems</i>
---	----------------------------------	---

This standard assumes the user is familiar with Telecommunications Distribution Systems, with the cable and hardware used in them, and with the installation of cabling in many different environments, including, but not limited to, LANs, MANs, and WANs as defined by the City. It is not intended as a training manual in telecommunication distribution systems or to replace existing industry standards.

III. DEFINITIONS

Authority Having Jurisdiction (AHJ) includes the fire marshal, building inspector, or any other local, state, or federal inspector having jurisdiction over a City facility.

Access Control and Monitoring Systems (ACAMS) monitors and controls the hardware used to secure the facilities at Sky Harbor Airport.

American National Standards Institute (ANSI) coordinates the U.S. voluntary consensus standards system, providing a neutral forum for the development of policies on standards issues and serving as a watchdog for standards development and conformity assessment programs and processes.

American Standard for Testing and Materials (ASTM) is an international standards organization that develops and publishes voluntary consensus technical standards for a wide range of materials, products, systems, and services.

American Wire Gauge (AWG) is used since 1857 predominantly in North America for the diameters of round, solid, nonferrous, electrically conducting wire.

Backbone Segment incorporates all hardware and components associated with connecting MTR's, TR's within a building, or connectivity between buildings.

Baggage Handling System (BHS) is a conveyor system installed in airports that transport checked luggage from ticket counters to areas where the bags can be loaded onto airplanes. A BHS also transports checked baggage from airplanes to baggage claims or to an area where the bag can be loaded onto another airplane.

Building Administered Outlet is a device not typically controlled directly by a local user. Examples include closed-circuit cameras, wireless access points, and building automation systems.

Building Industry Consulting Service International (BICSI) provides information, education, and knowledge assessment for individuals and companies in the Information and Communications Technology industry.

Cable Television (Community Access Television) (CATV) receives television broadcasts by the antenna and relays them by cable to paying subscribers.

Computer Aided Dispatch (CAD) is used for emergency dispatch of fire crews. Also known as the Fire Station Alerting System.

Carrier-Owned Distributed Antenna System (DAS) is a network of antennas that sends and receives cellular signals on a carrier's licensed frequencies, thereby improving voice and data connectivity for end-users.

Closed Circuit Television (CCTV) is a TV system in which signals are not publicly distributed but are monitored, primarily for surveillance and security purposes.

Domain: <i>INF Architecture</i>	Number: <i>200.215</i>	Standard Title: <i>Telecommunications Cabling Systems</i>
---	----------------------------------	---

Communications Plenum Cable (CMP) is a cable jacketed with a fire-retardant plastic jacket of either a low-smoke polyvinyl chloride (PVC) or a fluorinated ethylene polymer.

Common Use Passenger Processing System (CUPPS) enables airports, airlines, and their handling agents to access respective IT applications. From a user's perspective, the operation of Common Use Passenger Processing (CUPPS) is simple. After the workstation has been switched on, the user login screen is presented. The user enters a User ID and a password. These are validated and authenticated, and if successful, an application 'menu' is displayed. The content of the menu varies according to the user and their access rights.

Common Use Self-Service (CUSS) is an airport kiosk that can be dedicated to a specific airline or shared as common use by multiple airlines. The kiosk can be used for several self-service processes, including booking, changing a reservation, check-in, and bag tag printing.

Common Use Terminal Equipment (CUTE) is an IT solution that enables multiple airlines to use existing airport infrastructures to control passenger and flight processing through their own servers. CUTE is comprised of both CUSS and CUPPS equipment.

Electro Magnetic Interference (EMI) is a disturbance generated by an external source that affects an electrical circuit by electromagnetic induction, electrostatic coupling, or conduction.

Electrical Metallic Tubing (EMT) encompasses an unthreaded listed steel raceway of the circular cross-section. Also commonly called a thin-wall.

Equipment Room (ER) is an environmentally controlled centralized space for telecommunications equipment that usually houses a primary or intermediate cross-connect.

Electronic Visual Informational Displays (EVID) are dynamics signage used to show flight information, gate information, and many other types of information at the airport.

EZ Path is a fire-rated pathway that incorporates self-sealing intumescent pads that automatically adjust to the installed cable fill without user manipulation or maintenance.

Horizontal Segment are associated with connectivity from the MTR or TR to the work area.

House Fiber (HF) is a fiber optic cable installed within a building. Also referred to as an intra-building fiber cable.

Insulation Displacement Connector (IDC) is an electrical connector designed to be connected to the conductor(s) of an insulated cable by a connection process that forces a selectively sharpened blade or blades through the insulation, bypassing the need to strip the jacket.

International Electrotechnical Commission (IEC) is an international standard-setting body to develop, maintains, and promotes standards in Information Technology and Information and Communications Technology.

Intermediate Metal Conduit (IMC) is a threaded steel tubing heavier than EMT but lighter than a rigid metallic conduit.

International Standards Organization (ISO) is composed of representatives from various national standards organizations promoting worldwide proprietary, industrial, and commercial standards.

Local Area Network (LAN) is a network within a City facility or campus.

Domain: <i>INF Architecture</i>	Number: <i>200.215</i>	Standard Title: <i>Telecommunications Cabling Systems</i>
---	----------------------------------	---

Main Telecommunications Room (MTR) serves as the main inter-building termination point for communications services. The MTR is the room that houses the telecommunications equipment that meets the entire building's voice, data, and other low-voltage needs. This equipment may include the phone system, service provider equipment, LAN/MAN/WAN equipment, and video distribution equipment. It contains cross-connect facilities for terminating cables and connecting the horizontal and backbone segments to each other and telecommunications equipment. The MTR may also support other building information systems such as CATV, alarms, security, audio, and other telecommunications systems. An MTR can be co-located with a TR and/or a Building Entrance Facility and/or Equipment Room. MTR, ER, and EF specifications are identical for all three rooms.

Metropolitan Area Network (MAN) interconnects multiple City facilities, not within a campus, via City-owned fiber optic cable.

National Electrical Code (NEC) is a regionally adoptable standard for the safe installation of electrical wiring and equipment in the United States. It is part of the National Fire Codes series published by the National Fire Protection Association (NFPA), a private trade association.

National Fire Protection Association (NFPA) is a United States trade association, albeit with some international members, that creates and maintains private, copyrighted, standards and codes for usage and adoption by local governments.

Passenger Boarding Bridge (PBB) is an enclosed, movable connector that most commonly extends from an airport terminal gate to an airplane, and in some instances, from a port to a boat or ship, allowing passengers to board and disembark without going outside and being exposed to harsh weather.

Pedestrian Emergency Duress Systems (PEDS) are call boxes placed in public areas where patrons may need assistance. These calling units typically have a blue light that alerts responders to the location of the emergency.

Public Address System (PAS) sends prerecorded messages throughout the Airport. This is utilized to make announcements as well as fire alarm evacuation. Airlines have access to the page of the gate hold areas.

Remote Copper (RC) is a fiber optic cable that originates inside a building but terminates outside a building. Also referred to as an inter-building fiber cable.

Registered Communications Distribution Designer (RCDD) is a BICSI certification for an individual who has demonstrated knowledge in the design, integration, and implementation of telecommunications and data communications/technology systems and related infrastructures.

Remote Fiber (RF) copper cable that originates inside a building but terminates outside a building. Also referred to as an inter-building copper cable.

Radio Frequency Interference (RFI) is electromagnetic radiation emitted by electrical circuits carrying rapidly changing signals as a byproduct of their normal operation, which causes unwanted signals (interference or noise) to be induced in other circuits.

Telecommunications Industry Association (TIA) is accredited by ANSI to develop voluntary, consensus-based industry standards for various Information and Communication Technologies products, and currently represents nearly 400 companies.

Domain: <i>INF Architecture</i>	Number: <i>200.215</i>	Standard Title: <i>Telecommunications Cabling Systems</i>
---	----------------------------------	---

Telecommunications Ground Bar (TGB) is a predrilled copper busbar with standard NEMA bolt-hole sizing. It centrally connects systems and equipment served by a telecommunications room.

Telecommunications Main Ground Busbar (TMGB) is the dedicated extension of the building grounding electrode system for the telecommunications infrastructure. All telecommunications grounding busbars and associated equipment are bonded to the TMGB.

Telecommunications Room (TR) is dedicated to distributing horizontal cables on the floor it is located. A TR may also be used for intermediate and main cross-connects. It serves as the connection point between the work area and the MTR. The TR houses equipment for the voice, data, and other low voltage needs of one floor of a building. The TR may also support other building information systems such as CATV, alarms, security, audio/Video, 800 MHz radio, wireless systems, and low-voltage telecommunications systems. An MTR and TR may be co-located within the same room. Additional space, racks, and electrical and cable management are required to support the MTR.

Telecommunications Service Request (TSR) is a form in SAP used by departments to formally request services from ITS Unified Communications Section.

Underwriters Laboratories (UL) is a global independent safety science company with more than a century of expertise in innovating safety solutions from the public adoption of electricity to new breakthroughs in sustainability, renewable energy, and nanotechnology.

Unshielded Twisted Pair (UTP) is the most used copper cable. The twisted pair is the copper wire that connects the work area to the TR. To reduce crosstalk or electromagnetic induction between pairs of wires, two insulated copper wires are twisted around each other without a shield.

User Administered Outlet that serves devices typically controlled directly by a user. These outlets are usually installed in cubicles and within hard-wall offices. Examples include telephones, computers, and printers.

Wide Area Network (WAN) that interconnects multiple City facilities via service providers.

Domain: <i>INF Architecture</i>	Number: <i>200.215</i>	Standard Title: <i>Telecommunications Cabling Systems</i>
---	----------------------------------	---

IV. STANDARD

1.0 Information Technology Services (ITS) Responsibilities

1.1 ITS is responsible for all City inside and outside plant voice and data communications system facilities, network connectivity, and the associated backbone cabling per Administrative Regulation (A.R.) 1.73. These responsibilities include reviewing all project plans developed by others, including those mentioned in Table 1.

Project Plan	Description
Schematic	These are the initial planning documents and design drawings that assist departments in the early stage of the project. The Schematic Design documents shall consist of a system narrative, including MTR/TR information and campus connection points. The schematic design documents should also include drawings composed of a title single-line diagrams and site plans. These plans may be part of the overall site and or electrical plan. ITS shall be provided Schematic Design documents for review at each stage of the schematic design process and be provided a minimum of ten workdays from the date documents are received by ITS for review and return of comments.
Design Development	As the architectural design process progresses, overlays are developed to show the various structures and systems planned for the building. Design Development documents shall consist of outline specifications. Drawings should include a title sheet, single line diagram site plan, enlarged floor plans of the proposed MTR/TR and details. ITS shall be provided Design Development documents for review at each stage of the design development process and be provided a minimum of 15 workdays from the date documents are received by ITS for review and return of comments.
Construction Documents	These documents depict the final design before bid submittal is undertaken. The Construction Documents shall consist of a completed cabling specification and drawing set. ITS shall be provided Construction Documents for review at each stage of the construction document process and be provided a minimum of fifteen workdays from the date documents are received by ITS for review and return of comments.
Working Copy	The bid copy
Final Documentation and Drawings	These drawings and documents represent the project as it is finally constructed and delivered.

Table 1

2.0 The Telecommunications System Design and Install Process

This standard provides a minimum configuration that ITS uses when planning new construction, remodeling, and/or any ADDS, MOVES, OR CHANGES of an existing facility. ITS shall be consulted during the early planning phase of all projects.

Domain: <i>INF Architecture</i>	Number: <i>200.215</i>	Standard Title: <i>Telecommunications Cabling Systems</i>
---	----------------------------------	---

2.1 The Telecommunications Distribution System design process is broken down into eight segments, as shown in Table 2:

Segment	Description
Functional Requirements	The physical elements required to support telecommunications needs within a specific environment.
Horizontal Segment	Workstation outlets, cabling to the Telecommunications Rooms (TR), and all associated pathways.
Inside Plant Backbone Segment	Backbone cable and the sleeves, slots, and conduits enable the cable to pass from floor to floor: Main Telecommunication Room (MTR) to the TR.
Outside Plant Backbone Segment	The cabling and infrastructure that interconnects buildings on a campus or buildings within a metro area to form a Metropolitan Area Network (MAN).
Main Telecommunication Room (MTR), Equipment Room (ER), and Entrance Facility (EF)	The room houses common system equipment and hardware for terminating the campus and backbone cables. The Equipment Room (ER) provides space and maintains a suitable operating environment for large telecommunications and/or computer equipment. The Entrance Facility (EF) is the space or room where outside telecommunications utilities enter the building. This space is usually used as the demarcation point for telecommunications terminations for the building. These rooms may all be contained within the same space.
The Telecommunication Room (TR)	The hardware (i.e., patch panels, punch-down blocks, and racks) for terminating the cabling from the workstation outlets, electronic equipment, and Backbone cables.
Special Systems	Any cabling system used for devices outside traditional voice and data networks. Examples are Cable Television (CATV), Closed Circuit Television (CCTV), Fire Alarms, Access Control, and paging.
Infrastructure Documentation	A set of guidelines for documentation related to all cabling system projects (i.e., floor plans, splice details, jack numbers, etc.)

Table 2

3.0 Functional Requirements

3.1 Functional requirements generally refer to the physical elements required to support telecommunications needs within a specific environment. ITS shall determine the telecommunications infrastructure required. The expected life cycle for telecommunications infrastructure is a minimum of 15 years.

4.0 The Horizontal Segment

4.1 General design considerations for the Horizontal Segment include the following:

- 4.1.1 All 4-pair unshielded twisted pair (UTP) or fiber optic cables shall be installed using a star topology from the TR on each floor to every work area outlet. ITS shall approve all cable routes before installation.
- 4.1.2 All horizontal cables serving the floor areas shall originate from an MTR or TR.

Domain: <i>INF Architecture</i>	Number: <i>200.215</i>	Standard Title: <i>Telecommunications Cabling Systems</i>
---	----------------------------------	---

- 4.1.3 The horizontal cables shall be installed in cable trays, hard walls, surface mount raceways, conduits, and modular furniture poles. Pathways will be constructed from J-hooks and wire basket trays.
- 4.1.4 Wire basket tray is the preferred cable pathway. Cable pathways shall be designed to avoid sources of Electro Magnetic Interference (EMI) and Radio Frequency Interference (RFI) (i.e., fluorescent lighting fixtures, air handling motors, and power distribution panels).
- 4.1.5 Horizontal cables shall not be installed parallel to electrical conduits. Electrical conduits shall not be used as a method of support. Every cable, individual or many groups, shall be self-supported. Wherever possible, cable shall be grouped in pathways. Cable bundle quantities shall conform to NEC. Bundle sizes shall not exceed 36 cables. Velcro straps shall be used for cable management. Plastic cable ties shall not be used.
- 4.1.6 All material in plenum spaces shall be plenum rated.
- 4.1.7 In hard wall offices, cables are to be routed within walls. A vertical surface mount raceway shall be used if the cable cannot be installed within the wall.
- 4.1.8 At modular furniture workstations (cubicles), route horizontal cables within modular furniture poles and chases to non-metallic faceplates. A non-metallic gray or black liquid tight flexible conduit with a corresponding wall adapter will be used to protect the cable from the wall to the cubicle chase.
- 4.1.9 Horizontal cables for building administered outlets may be directly connected to devices using an eight-pin conductor modular plug (RJ45).
- 4.1.10 Horizontal cables for user-administered outlets shall not be connected directly to telecommunications equipment. Suitable connecting hardware (i.e., patch panels, patch cables, jack modules, and punch-down blocks) shall be used to make the connection to complete a channel link as defined in TIA 568. These outlets are typically installed at or below 72" above the finished floor (AFF).
- 4.1.11 The installation for all horizontal cables shall adhere to the specifications identified in the current Telecommunication Industry Association (TIA) 568 Commercial Building Wiring Standards and Building Industry Consulting Service International (BICSI) standards. Care shall be taken with installation not to over-pull, kink, and/or over-bend the cable. Care shall also be taken to ensure that during the installation, nicks, abrasions, burning, and scuffing of cable are prevented. Cables found to be damaged shall be replaced at the contractor's expense regardless of whether the cable passes Category 6 testing standards.
- 4.1.12 Care is required to manage the horizontal cable as it enters telecommunications rooms. All cables shall be neatly organized, routed, and secured with Velcro straps to the cable support systems and management hardware in an aesthetically pleasing manner. Cable shall have the appearance of being combed, with no tangles. Cable overlap shall be kept to a minimum.
- 4.1.13 All Category 6 cables shall be tested per Category 6 permanent link performance level standards. Complete testing shall be done on all horizontal cabling and backbone cabling between the MTR, TR, and workstations.
- 4.1.14 Category 6 termination methods shall be followed for termination at patch panels and work area outlets. Specific care shall be taken to maintain pair twists up to the point of termination within 1/2".

Domain: <i>INF Architecture</i>	Number: <i>200.215</i>	Standard Title: <i>Telecommunications Cabling Systems</i>
---	----------------------------------	---

- 4.1.15 Horizontal UTP cable shall never be spliced.
- 4.1.16 All conductive cabling and associated components shall comply with the current version of The National Fire Protection Association (NFPA) 75, National Electrical Code (NEC). Furthermore, all fiber optic cabling shall comply with Article 770 of the NEC.
- 4.1.17 Complete testing shall be done on all horizontal cabling and backbone cabling between the MTR/TR, Building entrance, and workstations.

4.2 The Configuration of Outlets (two configurations):

- 4.2.1 The **Single Drop** design consists of one (1) 8-pin conductor (8p8c) jacks or modular plug terminated on one (1) Category 6 plenum UTP cable. The cable shall be terminated on rack-mounted patch panels in the TR. Single drops will be terminated as the next available number on the patch panel and labeled as the A cable. The next port on the patch panel shall be left empty to accommodate a future B cable.
- 4.2.2 The **Dual Drop** design consists of two (2) 8p8c jacks terminated on two (2) Category 6 plenum UTP cables. Two (2) cables shall be terminated on a rack-mounted patch panel in the TR. Dual drops will be terminated as the next available number on the patch panel is labeled as cable A and B.

NOTE: If additional cables are required, dual drops can be added to the same faceplate. A new jack number may only be composed of A and B cables. Therefore, C and D cables are not permissible.

4.3 Cable Types and Lengths

- 4.3.1 Two types of cables shall be used in the horizontal segment:
 - 4.3.1.1 UTP cable will be 4-pair, 24 AWG, solid conductor cabling that meets current ANSI/TIA/EIA 568-B cabling specifications for Category 6/6A cable, to include any/all Amendments and Bulletins, and must meet specified specifications and performance requirements.
 - 4.3.1.2 Fiber optic cable will be single-mode or 50-micron laser-optimized multi-mode, graded index, and loose or tight-buffered cable.
 - 4.3.1.3 Approved manufacturers for copper and fiber include Berk-Tek copper/fiber, Superior Essex copper, Corning fiber, Prysmian fiber, or approved equal.
 - 4.3.1.4 All cables shall be installed per current TIA 568 building standards to the designated work area. All cable shall be terminated on Category 6 angled patch panels within the TR and on Category 6 rated 8p8c modular jacks or connectors at the work area.
 - 4.3.1.5 The maximum lengths of horizontal distribution cables, including the service loop from the work area to the TR, shall not exceed 295 feet.
 - 4.3.1.6 Patch cables and cross-connect jumpers in the TR will not exceed 20 feet.
- 4.3.2 Horizontal cabling shall conform with Underwriters Laboratories Incorporated (UL) Listed Type Communications Plenum Cable (CMP) or Outside Plant (OSP) as defined in the National Electrical Code. The cable sheath will be marked with the UL listing.
- 4.3.3 All patch cables and cross-connects that attach directly to active equipment shall meet the same or better performance requirements as the installed cabling system.
- 4.3.4 Care shall be taken to maintain minimum bending radii and to avoid kinking when dressing excess cable at termination locations.

Domain: INF Architecture	Number: 200.215	Standard Title: Telecommunications Cabling Systems
------------------------------------	---------------------------	--

- 4.3.5 Cable service slack of 8 feet shall be provided at both ends of cable runs to accommodate future cabling system changes when possible.
 - 4.3.6 Service slack placed during the installation of 4-pair horizontal cables shall be coiled neatly above the ceiling in a figure-eight configuration.
 - 4.3.7 Service slack placed during the installation of fiber optic cables should be coiled neatly above the ceiling in a large loop configuration that will meet the manufacturer's minimum bend radius requirements.
- 4.4 Termination of Hardware Requirements at the Outlet
- 4.4.1 Each UTP plenum or OSP Category 6 cable will terminate all four pairs at the outlet with an 8-pin, 8-conductor universal T568 modular jack or plug. Modular plugs shall be used for facility-administered outlets (i.e., CCTV, card access, Wi-Fi). All jacks, plugs, and patch panels will be terminated in a T568-B configuration.
 - 4.4.2 Faceplates for any designated outlets shall be from the same manufacturer with coinciding part numbers for the jacks being used.
 - 4.4.3 Faceplates shall be a single-gang 2-position configuration for hard walls and furniture applications.

AVIATION-SPECIFIC REQUIREMENT FOR SECTION 4.4

Wireless Access Points (WAP) locations shall use a four-square ceiling box with a minimum depth of 3-1/2". Inside the box, four-pair plenum cables shall terminate on a single-position Ortronics surface mount box. A maximum 8' whip should be secured to a ceiling tile grid bracket. The ceiling tile grid bracket shall contain a four-square ceiling box with an industry-standard mud ring to mount the end device.

See [Section 7](#) for special systems-specific termination hardware requirements.

- 4.4.4 Closed-Circuit Television (CCTV Cameras) ceiling locations shall also use a four-square ceiling box with a minimum depth of 3-1/2". Inside the box, a four-pair plenum cable shall terminate on a single-position Ortronics surface mount box. A maximum 8' whip should be secured to a ceiling tile grid bracket. The ceiling tile grid bracket shall contain a four-square ceiling box with an industry-standard mud ring to mount the end device.
- 4.4.5 CCTV wall locations, where aesthetics is not a concern, shall also use a surface mount four square box with a minimum depth of 3-1/2". Inside the box, four-pair of plenum cables shall terminate on a single-position Ortronics surface mount box. A maximum 8' whip shall be secured within or to the wall. Refer to manufacturer specifications for camera mounting instructions.
- 4.4.6 Building Management System (BMS) locations shall use a surface mount of four square boxes with a minimum depth of 3-1/2" where a single position Ortronics surface mount box shall be mounted. BMS contractor shall provide a pathway and patch cord from the surface mount box to the ethernet port on the device.
- 4.4.7 Power Over Ethernet (POE) Lock locations shall use a recessed four-square box with a minimum depth of 3-1/2" where a single position Ortronics surface mount box shall be mounted. The lock hardware contractor shall provide a pathway and patch cord from the surface mount box to the ethernet port on the device.

Domain: <i>INF Architecture</i>	Number: <i>200.215</i>	Standard Title: <i>Telecommunications Cabling Systems</i>
---	----------------------------------	---

- 4.5 Workstation Identification
 - 4.5.1 The workstation identification labeling scheme is assigned by ITS and is crucial to the structured cabling system.
 - 4.5.2 Workstation identification shall be labeled with either computer-generated labels or by an ITS-approved label maker. No workstation identification numbers will be handwritten. All labels shall be black lettering on white tape.
 - 4.5.3 Workstation identification numbers are to be completed at the beginning of Construction Document preparation. The installation contractor shall develop a hard copy of the workstation identification numbers.
 - 4.5.4 The workstation identification number will be placed on the faceplate and panel at the entry of a cubical area. Hard wall offices will have a label placed approximately 60" above the finished floor on the hinged side of the door frame.
 - 4.5.5 All cables shall be labeled with a computer-generated label within 4" of the Jack and within 2" to 4" from the Patch Panel. Cable 1 will be labeled with an (A); Cable 2 will be labeled with a (B) (Example: PCH-01NC001A PCH-01NC001B).
- 4.6 Structures for Supporting the Horizontal Cabling
 - 4.6.1 Special attention shall be given when designing and installing the type and layout of structures to support the horizontal cabling. The design and installation shall accommodate all foreseeable cabling changes needed for future capacity and applications.
 - 4.6.2 The City of Phoenix requires that the spaces above the ceiling grid and under a raised floor shall be used to route the horizontal cabling.
 - 4.6.3 Hard walls and power poles shall be used in the work area for vertical pathways.
 - 4.6.4 Freestanding relay racks, Heavy Duty 19" x 84", drilled on both sides per TIA with universal thread standards, properly anchored will be used. Wall mount racks can only be used with ITS written approval.
 - 4.6.5 When cable tray is not feasible to install, cable supports (J-Hooks) or pipe (EMT or IMC if required) shall be used. J-Hooks shall be installed by means that are structurally independent of the suspended ceiling, its framework, or supports. These cable supports shall be spaced no more than 5 feet apart.

AVIATION-SPECIFIC REQUIREMENT FOR SECTION 4.6.5

J-Hooks shall not be used within Aviation facilities. A cable tray shall be utilized for the main pathway with extensions to wall outlets in a minimum ¾" conduit.

- 4.6.6 If cable tray is not feasible, then conduit shall be utilized for the entire pathway.
- 4.6.7 Cable trays shall be wire basket trays. They shall be at least 18-inches wide and 2 inches deep. Smaller buildings and secondary tray sections serving fewer than 50 work areas may utilize a 12-inch-wide tray.
- 4.6.8 In the TR, a wire basket tray shall be used for cable management and rack support. Velcro cable ties shall be used to create a neat and practical installation. Bundle sizes shall conform to NEC.
- 4.6.9 Cable trays shall be secured on 5-foot centers using standard trapeze or angled wall bracket support.

Domain: <i>INF Architecture</i>	Number: <i>200.215</i>	Standard Title: <i>Telecommunications Cabling Systems</i>
---	----------------------------------	---

- 4.6.10 It is important that the path for the cable tray is free and clear of obstructions, such as HVAC ducts, large pipes, and structural beams within the building. Specified Technologies, Inc. EZ Path fire-rated pathways or approved equivalent shall be used to penetrate fire-rated walls.
- 4.6.11 Cable trays shall be grounded and bonded as required by the manufacturer and NEC.
- 4.6.12 Cable trays will not be placed within 5 inches of any overhead light fixture and within 12 inches of any electrical ballast.
- 4.6.13 Cable trays shall not be installed parallel to the building lighting system.
- 4.6.14 A minimum clearance of 8 inches above the cable tray shall be maintained at all times. All bends and joints in the cable trays shall be fully accessible.
- 4.6.15 A minimum size $\frac{3}{4}$ inch EMT conduit shall be used from hard wall workstation outlets and stubbed into the nearest accessible ceiling space. Furniture feed cables will be installed in either a power pole or down a wall with the appropriate conduit size. Conduit shall not exceed the industry standard 40% fill ratio. Calculations shall be based on manufacturers' specifications.
- 4.6.16 All firewalls requiring penetration for low voltage cabling pathways shall be fire-stopped in accordance with the NEC NFPA-75 and all local and statutory codes. Use of STI EZ Path products or approved equivalent is required. If EZ Path cannot be used, sleeves with connectors and plastic bushings on both ends and be properly anchored to walls (e.g., anchored Unistrut with strut clamps) shall be used. Every fire stop location shall be a UL-listed solution and labeled accordingly at each penetration.
- 4.6.17 Conduit will be installed with a pull string with a minimum test rating of 200 pounds.
- 4.6.18 The ends of all conduits will be reamed and have connectors to eliminate sharp edges that can damage cables during installation.
- 4.6.19 Conduit runs shall be designed and installed to:
 - 4.6.19.1 Follow the most direct route possible with no more than two 90-degree bends between pull points.
 - 4.6.19.2 Contain no continuous sections longer than 100 feet. Pull points shall be used for runs that exceed 100 feet in length. Pull box sizes shall be specified to meet the bend radius requirements for the cable.
- 4.6.20 Conduit shall be bonded to the ground on one or both ends.
- 4.6.21 Conduit shall not be installed through areas where flammable materials may be stored, over, or adjacent to boilers, incinerators, hot water lines, or steam lines.
- 4.6.22 The radius of a conduit bend shall be at least 6 to 10 times the diameter of the conduit, depending on its size. Choose the bend radii for the conduit using the cable manufacturer's specifications for installation.
- 4.6.23 A 4"x4"x2 1/2" back box with a single gang plaster ring shall be used at each work area for cable installations.
- 4.6.24 A metal/plastic single gang box eliminator will be required for existing installations.
- 4.6.25 For additional information on conduit bend radius requirements and recommendations, see specifications in ANSI/NFPA 75 and TIA 569.
- 4.6.26 Cable tray shall not be used in an exposed outdoor environment.
- 4.6.27 Cable tray shall only be used for low voltage cabling. Dividers are to be used to separate cable types and systems, as shown in Table 3.

Domain: INF Architecture	Number: 200.215	Standard Title: Telecommunications Cabling Systems
------------------------------------	---------------------------	--

AVIATION-SPECIFIC REQUIREMENT FOR SECTION 4.6

Conduit shall be factory anodized in color as stated below. Where the conduit system is painted, all junction boxes shall be required to be painted to match the system color. On junction boxes that are larger than 16 inches square, only the cover of the box needs to be painted.

Conduit Type	Color
Power – Normal System	None (Galvanized)
Emergency Power – All Systems	Orange
Communications/Data	Yellow
HVAC Controls/BMS	White
Fire Alarm/Life Safety	Red
Public Address System (PAS)	Blue
PAS used for Fire Alarm	Blue with Double Red Stripe
Access Control and Monitoring	Green

Table 3

5.0 The Inside Plant Backbone Segment

5.1 General Design Considerations for the Inside Plant Backbone Segment:

- 5.1.1 The Inside Plant Backbone Segment provides copper and optical fiber connectivity between the MTR, EF, and the MTR to the TR.
- 5.1.2 The Inside Plant Backbone Segment consists of the backbone cable and the supporting infrastructure within a building.
- 5.1.3 All copper backbone cables shall be terminated on a 110-type termination block in the MTR and in the TR for all new construction. A 66-style punch-down block will be accepted for installations on existing termination blocks.
- 5.1.4 All punch-down blocks shall be wall-mounted on a minimum of 4ft x 8ft x ¾ in. A/C rated fire-retardant-treated plywood with stamp clearly visible, on all applicable walls of the MTR and the TR. Non-fire-retardant treated plywood may be used if plywood is painted with 2 coats of fire-retardant paint. The stamp on any painted fire-retardant-treated plywood shall remain visible.

AVIATION-SPECIFIC REQUIREMENT FOR SECTION 5.1.4

Fire-retardant treated plywood painted with 2 coats of fire-retardant paint shall be used. The stamp on any painted fire-retardant-treated plywood shall remain visible.

- 5.1.5 Inside plant copper backbone cables shall consist of 24 AWG, category 3 or better, multi-pair cables, riser, or plenum rated as applicable.
- 5.1.6 All single-mode backbone fiber shall be terminated using SC connectors. All multimode backbone fiber shall be terminated using LC connectors.

Domain: <i>INF Architecture</i>	Number: <i>200.215</i>	Standard Title: <i>Telecommunications Cabling Systems</i>
---	----------------------------------	---

AVIATION-SPECIFIC REQUIREMENT FOR SECTION 5.1.7

Multimode fiber shall not be used within Aviation facilities.

- 5.1.7 Multi-pair copper, multimode fiber (OM3/OM4), and single-mode fiber (OS1/OS2) is acceptable for backbone cabling.
- 5.2 The Size of the Copper Backbone Cable
- 5.2.1 The backbone cable's size depends on the number of service provider circuits (i.e., DSL, 1FB, etc.) being supported by the TR on that floor.
- 5.2.2 The most commonly available cable sizes are 25, 50, and 100 pairs.
- 5.2.3 The minimum number of copper cable pairs required for each type of outlet is project specific and will be determined by ITS during the design phase.
- 5.3 The Size of the Fiber Optic Backbone Cable
- 5.3.1 The size of the fiber optic cable from the MTR to the TR will be no less than a 12-strand multimode or single-mode. ITS shall determine the fiber type during the design phase.

AVIATION-SPECIFIC REQUIREMENT FOR SECTION 5.3

Each fiber cable routed to each TR shall be comprised of (2) 72 strands of single-mode fiber in diverse pathways.

- 5.4 Structures to Support Vertically Aligned TR
- 5.4.1 TR's that are vertically aligned shall be connected with EZ Path or approved equivalent.
- 5.4.2 Floor penetrations shall be positioned a minimum of 4 inches away from the near wall on which the backbone cables can be supported.
- 5.4.3 Penetrations shall not be placed directly above or below the termination fields.
- 5.4.4 All floor penetrations installed shall conform to the NFPA, NEC, and local fire codes.
- 5.4.5 Penetrations shall always be properly fire-stopped using a UL-listed solution in accordance with all applicable building codes.
- 5.4.6 If sleeves are used, they shall have connectors on both ends and be properly anchored to walls (e.g., anchored Unistrut with strut clamps).
- 5.4.7 STI EZ Path or approved equivalent sleeves shall be used whenever possible. If conduit sleeves are required, they shall be 4 inches in diameter unless a structural engineer requires a smaller size or obstructions are present and equipped with pull strings. Sleeves shall not exceed 40% of the conduit fill ratio.
- 5.5 Structures to Support Horizontally Offset TR
- 5.5.1 ITS recommends stacking all TRs within a building; ITS also understands that there are times when this is not possible.
- 5.5.2 TRs that are not vertically aligned shall be connected with cable trays and/or conduits.
- 5.5.3 ITS shall determine the number of conduits required. Conduit capacity shall not exceed a 40% fill ratio.
- 5.5.4 Pull boxes are required in sections of conduit 100 feet or more in length or containing more than two 90° bends. Pull boxes shall not be used in lieu of a bend.

Domain: <i>INF Architecture</i>	Number: <i>200.215</i>	Standard Title: <i>Telecommunications Cabling Systems</i>
---	----------------------------------	---

- 5.5.5 Cable trays and conduit that are used to support horizontal cabling may be used to support backbone cables provided the following conditions are met:
 - 5.5.5.1 The cable trays' carrying capacity can accommodate the backbone cables.
 - 5.5.5.2 The backbone cables shall be UL Listed Type CMP if they are installed in air-handling plenums without conduit.
 - 5.5.5.3 The backbone cables conform to NEC and comply with the State of Arizona and other AHJ fire codes as interpreted by the State Fire Marshal's department.
 - 5.5.5.4 Conduit shall be used to route the backbone cables between the TR wherever feasible.
 - 5.5.5.5 Conduit shall be grounded and bonded at each end.
 - 5.5.5.6 Conduit shall be installed with a mule tape with footage markers and connectors at both ends to protect the cable from damage.
- 5.5.6 Cable trays and conduits that enter the TR shall be placed near the corner and as close as possible to the wall where the backboard is mounted to allow for proper cable racking and to minimize the cable route inside the TR.
- 5.5.7 Cable trays and conduits in the ceiling shall protrude into the TR 4 inches and a minimum of 7 ½ feet above the finished floor.
- 5.5.8 All backbone cables are to be labeled based on a cable number assigned by ITS.
- 5.5.9 Performance tests are required for acceptance of newly installed cables. All field testing shall comply with the latest version of the TIA 568 Commercial Building Telecommunications Wiring Technical Service Bulletin specification.

AVIATION-SPECIFIC REQUIREMENT FOR SECTION 5.5

A cable tray shall not be used for backbone cabling; it is to be installed in a dedicated conduit.

6.0 The Outside Plant Backbone Segment

6.1 General Design Considerations

- 6.1.1 The Outside Plant Backbone Segment consists of the cables and structures needed to interconnect building-to-building and building-to-metro area distribution frames (MADFs). It includes underground conduits, underground cables, splice boxes, manholes, pull boxes, outside terminals, and support structures.
- 6.1.2 ITS shall be consulted during a project's early utilities planning phase to provide technical requirements for the Outside Plant Backbone Segment.
- 6.1.3 ITS shall be responsible for the review and approval of all cable routes from building to building, cable distribution methods, underground cable requirements, types of cable used in the segment, splice cases, manhole and pull box requirements, and electrical protection and bonding/grounding requirements.
- 6.1.4 All Outside Plant Backbone Segments shall be designed and installed to BICSI Telecommunications Distribution Methods Manual (TDMM), BICSI Customer-Owned Outside Plant manual, and TIA-758 Specifications for Outside Plant Construction.

Domain: <i>INF Architecture</i>	Number: <i>200.215</i>	Standard Title: <i>Telecommunications Cabling Systems</i>
---	----------------------------------	---

6.2 Cable Distribution

- 6.2.1 ITS shall review and approve the cable distribution method along a proposed cable route. All Outside Plant cabling shall be placed in conduits. Neither direct buried nor aerial cable are approved distribution methods.

AVIATION-SPECIFIC REQUIREMENT FOR SECTION 6.2

The use of FAA duct banks for underground routing may be an option through the Airport's Joint Use Agreement with the FAA. Aviation will work with FAA on all OSP designs when utilizing joint vaults for Outside Plant Cable Distribution.

Conduit Requirements

- 6.2.2 Underground cabling in conduit cable projects shall be installed based on engineering drawings approved by ITS.
- 6.2.3 All submitted drawings and documentation shall include the following:
- 6.2.3.1 Submittals and/or details of a typical trench cross section showing cable and duct locations in the trench, clearances from final grade, backfill materials and depths, pavement cutting information, and compacting requirements for both paved and unpaved areas.
 - 6.2.3.2 Construction notes applicable to the work being performed.
 - 6.2.3.3 Scale drawings showing location ties to existing structures, cable, conduit, utility boxes, and any conflicting substructures and profile drawings of congested areas where vertical and horizontal separation from other utilities is critical during cutting and placing operations.
 - 6.2.3.4 Legends explaining symbols of all relevant structures and work operations.
 - 6.2.3.5 Cable type and counts, and directions of feed.
 - 6.2.3.6 Conduit types, dimensions, and wall-to-wall measurements when used with pull boxes or manholes.
- 6.2.4 All areas around the conduit entrances shall be free of any construction, storage, or mechanical apparatus.
- 6.2.5 Conduit stubs entering the building shall extend beyond the perimeter landscaping. All conduit ends adjacent to the building shall be flagged for easy identification.
- 6.2.6 All unused entrance conduits shall be capped and installed with a minimum 1250-pound detectable mule tape. A tracer wire installed outside the conduit is also acceptable.
- 6.2.7 Conduit entering from a below grade point shall extend 4 inches above the finished floor.
- 6.2.8 All cables entering a building shall conform to the grounding and bonding requirements listed in NEC Articles 250 and 800.
- 6.2.9 All utilities shall be identified and located prior to any digging, including all subsurface facilities such as power, gas, water, traffic, and outdoor lighting.
- 6.2.10 Orange warning tape containing metallic tracings shall be placed a minimum of 18 inches above the buried conduits to minimize any chance of an accidental dig-up.
- 6.2.11 The minimum depth of a trench shall allow 36 inches of cover from the top of the conduit to the final grade point. See NEC 300 for conditions pertaining to other depths. Thirty-six (36) inches of half-sack slurry is recommended. For trench detail information, see [Figure #1](#).

Domain: <i>INF Architecture</i>	Number: <i>200.215</i>	Standard Title: <i>Telecommunications Cabling Systems</i>
---	----------------------------------	---

- 6.2.11.1 The following minimum vertical or horizontal separations shall be maintained between telecommunications facilities and other facilities sharing a common trench.
- 6.2.11.2 Power or other foreign conduits: 3 inches of concrete, 4 inches of masonry, or 12 inches of well-tamped earth.
- 6.2.11.3 Pipes such as gas, oil, and water: 6 inches when crossing, 12 inches when parallel.
- 6.2.11.4 Railways: 3 feet below the top of rails.
- 6.2.12 Conduit shall be encased in concrete when the following conditions exist:
 - 6.2.12.1 Minimum conduit depth cannot be attained.
 - 6.2.12.2 Conduit shall pass under roads, driveways, railroad tracks, or when bend points are subject to movement.
 - 6.2.12.3 Conduit contains high-priority/mission-critical services as determined by ITS.

AVIATION-SPECIFIC REQUIREMENT FOR SECTION 6.3.11

Refer to Aviation Underground Standard for more information on encasing the conduit in concrete.

- 6.2.13 Reinforcing bars and/or crutches within the concrete shall be used at any location subject to potentially extreme stress.
- 6.2.14 The conduit shall be sealed inside the building to prevent rodents, water, or gases from entering the building.
- 6.2.15 All bends shall be long, sweeping bends with a radius not less than 6 times the internal diameter of a conduit 2 inches or smaller, or 10 times the internal diameter of a conduit larger than 2 inches.
- 6.2.16 Underground conduit shall be PVC Schedule 40, corrosion-resistant plastic.
- 6.2.17 There shall be no more than two 90-degree bends or 600 feet between pulling points on all underground cables without prior ITS approval.
- 6.2.18 Conduit bends that extend above ground shall be metallic.
- 6.2.19 All metallic conduits shall be reamed, bushed, and capped.
- 6.2.20 Metal conduits through foundation floors and/or walls shall extend to undisturbed earth to prevent shearing.
- 6.2.21 All open conduits shall be provided with a continuous run of 2500-pound detectable mule tape.
- 6.2.22 The minimum number of conduits for any installation of the cable shall be two 4-inch conduits with a continuous 2500-pound detectable mule tape.
- 6.2.23 All fiber or copper conduits shall provide a continuous run of 2500-pound detectable mule tape.
- 6.2.24 Contractor shall schedule an inspection with a minimum of 48-hour advance notice with ITS after conduit and manholes are installed but before slurry and dirt backfill.
- 6.2.25 All underground conduits shall be mandrel and free of debris prior to acceptance. The contractor shall notify ITS with a minimum of 48-hour advance notice prior to the mandrel start date.

Domain: <i>INF Architecture</i>	Number: <i>200.215</i>	Standard Title: <i>Telecommunications Cabling Systems</i>
---	----------------------------------	---

6.3 Cable Requirements

- 6.3.1 Two types of cable are approved for use in the Outside Plant Backbone Segment: multi-pair copper cable and fiber optic cable.
- 6.3.2 All underground copper cable requires an armored sheath to resist rodent and penetration-type damage.
- 6.3.3 All cables shall be marked with the cable length, cable code, date, and location of the manufacturer.
- 6.3.4 Outdoor optical fibers shall be contained in loose buffer tubes with each buffer tube containing 12 fibers. The fibers shall not adhere to the inside of the buffer tube. Each fiber shall be distinguishable by means of color coding in accordance with EIA- 598-, Optical Fiber Cable Color Coding.
- 6.3.5 The cable shall contain at least one ripcord under the inner sheath and under the steel armor for armored cable.
- 6.3.6 All cable jackets or sheaths shall be free of holes, splits, and blisters.
- 6.3.7 The cable jacket shall contain no metal elements and shall be of a consistent thickness.
- 6.3.8 The actual length of the cable shall be within -0/+1% of the length markings.
- 6.3.9 The cable jacket of a cable containing two different fiber types (hybrid construction) shall be marked to indicate the quantity of each fiber type, the identity of each fiber type, and the fiber sequence.
- 6.3.10 The manufacturer's maximum pulling tensions shall not be exceeded during cable installation.
- 6.3.11 ITS-approved manufacturers include Corning, Berk-Tek, Essex, AFL, Prysmian, or approved equivalent.
- 6.3.12 ITS approved fiber types are OM3 and OM4 laser optimized, and single-mode fiber.
- 6.3.13 All single-mode backbone fiber shall be terminated using SC connectors. All multimode backbone fiber shall be terminated using LC connectors.

6.4 Manhole and Handhole Requirements

- 6.4.1 A standard minimum manhole size shall be 4 feet wide, 4 feet long, and 4 feet deep. See [Figure #2](#) for more information.
- 6.4.2 A standard hand hole size shall be 28 inches wide, 38 inches long, and 38 inches deep. See [Figure #8](#) for more information.
- 6.4.3 Manholes shall be used when a pull point is needed within any right of way, when a splice is needed, or when a conduit in excess of 3 inches in diameter is installed. Hand holes shall be used in landscape areas where conduits 3 inches or less in diameter are installed. ITS will make the final determination on which type of pull point is required.
- 6.4.4 The required traffic rating for each manhole and handhole shall be appropriate for each location. For detailed information regarding traffic-rated lid specifications, cable racking, and manholes, see [Figure #2](#).

AVIATION-SPECIFIC REQUIREMENT FOR 6.5.4

Aircraft-rated lids shall be used as required. See [Figure #4](#) for more information.

Domain: <i>INF Architecture</i>	Number: <i>200.215</i>	Standard Title: <i>Telecommunications Cabling Systems</i>
---	----------------------------------	---

7.0 The Main Telecommunications Room (MTR), Equipment Room (ER), and Entrance Facility (EF)

7.1 Design Requirements

- 7.1.1 Rooms shall adhere to requirements defined in the NEC, NFPA 75, and other applicable codes.
- 7.1.2 Minimum ceiling height shall be 8 feet, 6 inches.
- 7.1.3 The doors shall be a minimum of 3 feet wide and 6 feet, 8 inches tall. The doors must be lockable.
- 7.1.4 The floor shall be sealed concrete or static dissipative tile to minimize dust and static electricity.
- 7.1.5 Environmental requirements
 - 7.1.5.1 Rooms shall contain continuous and dedicated environmental control (24 hours per day, 365 days per year). The heating, ventilation, and air conditioning system shall maintain the room temperature between 64° F and 75° F. The relative humidity shall be sustained between 30% and 55%.
 - 7.1.5.2 Ensure that the air handling system for the equipment rooms can provide positive airflow and cooling, even during times when the main building systems are shut down. These units should be located outside of the room.
 - 7.1.5.3 Provide split system air conditioning units that follow the sequence of operation indicated on the Contract Drawings for each equipment room space.

AVIATION-SPECIFIC REQUIREMENTS FOR 7.1.5.3

- Provide redundant split system air conditioning units that follow the sequence of operation indicated on the Contract Drawings for each equipment room space.
- Air handlers are to be thermostatically controlled.
- Provide heating, ventilation, and air conditioning sensors and control equipment that are monitored by a monitoring system.

- 7.1.6 The room should not have a drop tile or other false ceiling. An open ceiling is preferred.
- 7.1.7 The lighting shall provide a minimum of 50-foot candles when measured 3 feet above the finished floor.
- 7.1.8 All light fixtures shall be mounted at least 8 feet, 6 inches above the finished floor.
- 7.1.9 All controls and light switches shall be located inside the room.
- 7.1.10 All walls shall be lined with 3/4-inch fire-treated plywood with a stamp clearly visible. 3/4-inch A/C Grade non-treated plywood can be used if painted with two coats of white fire-retardant paint. The plywood shall be securely fastened to the wall-framing members.

AVIATION-SPECIFIC REQUIREMENT FOR SECTION 7.1.10

Fire-retardant treated plywood painted with 2 coats of fire-retardant paint shall be used. The stamp on any painted fire-retardant treated plywood shall remain visible.

- 7.1.11 The room shall be provided with an electrical ground pursuant to NEC Article 250 and TIA-607.

Domain: <i>INF Architecture</i>	Number: <i>200.215</i>	Standard Title: <i>Telecommunications Cabling Systems</i>
---	----------------------------------	---

- 7.1.12 Acoustic noise levels in the room shall be maintained to a minimum by locating noise-generating equipment outside the MTR.
- 7.1.13 A pre-action “dry” pipe sprinkler system is required.
- 7.1.14 All water pipes transiting the room shall be removed or contained for existing structures. For new construction, all piping shall be designed not to enter the room.
- 7.1.15 The rooms shall not be used as a pass-through for any other building systems. All piping shall be designed not to enter the room and be routed to the room’s exterior.
- 7.1.16 The rooms shall be protected from contaminants and pollutants that could affect the operation and material integrity of the installed communications equipment.
- 7.1.17 If contaminants are present in concentrations greater than indicated in TIA-569-B, provide vapor barriers, positive room pressure, or absolute filters.

AVIATION-SPECIFIC REQUIREMENTS FOR SECTION 7.1

- In the MTR, doors shall be on ACAMS and a card reader shall be provided on both the inside and outside of the room as the badge swipe process will need to be performed for both ingress and egress. Provision for emergency exiting of the room shall be made available. In the event of a power outage, the Aviation Department would require that the door be designed to a no-lock status.
- In the TR, doors shall be on ACAMS and a card reader shall be provided outside of the room as the badge swipe process will need to be performed for ingress.
- Door signage must be consistent with Aviation Department practices.
- The MTR shall have one CCTV camera located on the inside and one on the outside of the room. Both shall be located to clearly monitor the door.
- The TR shall have one CCTV camera located on the outside of the room.
- The MTR shall be on separate fire protection loops and a gaseous fire protection system such as FM-200 or FE-25 shall be used. Consult with Facilities and Services on the use of gaseous systems.

7.2 Room Size

- 7.2.1 The size of the room depends on the size and variety of the equipment to be installed and the size of the area that the room will serve. The room shall provide enough space for all planned equipment and cables, including any environmental control equipment, power distribution units/conditioners, and uninterrupted power supply systems that will be installed in the room.
- 7.2.2 The room shall be sized according to the equipment’s needs and not by the square footage of the floor or building. The minimum size of the MTR should be 10 feet X 12 feet.

AVIATION-SPECIFIC REQUIREMENTS FOR SECTION 7.2.2

The minimum size of the MTR shall be 15 feet X 20 feet.

Additional floor space shall be required for applications such as video cabling and equipment, fire alarm panels and/or building monitoring equipment.

Domain: INF Architecture	Number: 200.215	Standard Title: Telecommunications Cabling Systems
------------------------------------	---------------------------	--

7.2.2.1 The minimum TR sizes shown are based on providing telecommunications service to one individual work area of 100 square feet as specified in the BICSI Telecommunications Distribution Methods Manual (TDMM). See Table 4 for more information

AVIATION-SPECIFIC REQUIREMENT FOR SECTION 7.2.2.1
The minimum size of the TR shall be 10 feet X 12 feet.

Telecommunications Distribution Methods Manual	
5,000 square feet or less	10 feet x 8 feet
5,000 to 8,000 square feet	10 feet x 10 feet
8,000 to 10,000 square feet	10 feet x 12 feet

Table 4

- 7.2.3 Additional floor space in the TR shall be required for applications such as video cabling and equipment, paging equipment, DAS, fire alarm panels, and/or building monitoring equipment.
- 7.2.4 Devices must be located within 250 feet of the TR, allowing 30 feet within the TR to route cables and service slack at the end device. This includes all building-mounted devices as well as Passenger Boarding Bridge devices.

7.3 Room Locations

- 7.3.1 The MTR shall be located on the first floor and as close as possible to a building entrance so that it is accessible for the delivery of large equipment.
- 7.3.2 The rooms shall not be located within or immediately adjacent to any space that may be subject to water or steam infiltration, humidity from nearby water or steam, heat, and any other corrosive atmospheric or environmental conditions such as toilets, drop sinks, or water heaters.
- 7.3.3 The rooms shall not be located near electrical power supply transformers, motors, generators, transmitters, radar transmitters, induction heating devices, and other potential sources of electromagnetic interference.
- 7.3.4 The rooms shall not share space in or be located near electrical closets, boiler rooms, washrooms, janitorial closets, or storage rooms.
- 7.3.5 There shall be one MTR per facility. Additional EFs or ERs may be required.
- 7.3.6 The TR is the main focal point for communications services serving a specific floor and shall be designed as an integral part of the overall building.
- 7.3.7 The TR shall be located as close as possible to the center of, and on the same floor as, the workstation area it serves to minimize the horizontal cable lengths.
- 7.3.8 Access to the rooms shall be directly from hallways and not from conference rooms, offices, electrical spaces, or mechanical spaces.
- 7.3.9 All water pipes transiting the room shall be removed or contained for existing structures. For new construction, all piping shall be designed not to enter the room.
- 7.3.10 TRs shall be stacked vertically in a multi-story building.
- 7.3.11 When secure and controlled access to a TR cannot be guaranteed, free-standing or wall-mounted lockable cabinets will be used.

Domain: <i>INF Architecture</i>	Number: <i>200.215</i>	Standard Title: <i>Telecommunications Cabling Systems</i>
---	----------------------------------	---

- 7.3.12 Free-standing or wall-mounted lockable cabinets shall be used in joint-use facilities or in facilities not owned by the City of Phoenix where non-City staff has access to a TR.
- 7.3.13 Where conduit for other systems (i.e., fire alarm, HVAC, lighting) must enter the room, it must travel as high as possible within the room, at the top of the wall.

7.4 Termination Hardware Requirements

- 7.4.1 Relay racks shall be freestanding, properly anchored relay racks, heavy duty 19" x 84", drilled on both sides per TIA universal thread standards, rack unit markings. Each relay rack shall be equipped with an attached 6-inch-wide vertical management trough with a bi-directional opening cover.
- 7.4.2 Cabinets are used instead of equipment racks based on security or other necessary factors.
- 7.4.3 The space for voice and data cable terminations shall be on one continuous wall or rack.
- 7.4.4 A clear space of at least 8 inches above and below the connecting hardware shall be provided for cabling handling.
- 7.4.5 There shall be additional backboard space for routing cables, patch cables, and/or cross-connects.
- 7.4.6 Termination hardware shall be wall-mounted, or rack-mounted in either equipment racks or enclosed data cabinets.
- 7.4.7 The horizontal data cabling shall be terminated on 110-type independent insulation displacement connectors (IDC) placed in patch panels for data cabling.
- 7.4.8 All UTP data cables shall be terminated on 48 fixed port angled high-density Category 6 patch panels which are mounted on wall racks, in a free-standing equipment rack, or in an enclosed data cabinet. Cables shall be terminated in the T568-B configuration.
- 7.4.9 For smaller installations, smaller port density patch panels can be used if approved by ITS.
- 7.4.10 Patch panels shall be clearly labeled with a typed or computer-generated label above the 8p8c module.
- 7.4.11 The approved manufacturer for all data patch panels are Ortronics or an ITS-approved equivalent.
- 7.4.12 110-type Wiring Blocks for all voice cabling will be used if a separate voice cable is needed.
- 7.4.13 The connecting block shall support the appropriate Category 6 applications and will use either cross-connect wire or patch cables.
- 7.4.14 The blocks shall be made of flame-retardant thermoplastic, with the base consisting of horizontal index strips for the termination of up to 25 pairs of conductors.
- 7.4.15 The block shall be available in 50-, 100-, and 300-pair sizes and have detachable standoff legs.
- 7.4.16 The blocks shall have termination strips on the base to be notched and divided into 4- or 5-pair increments.
- 7.4.17 The block shall have clear label holders with the appropriate inserts available. The insert labels provided with the blocks shall contain vertical lines spaced on the basis of circuit size (1-, 3-, 4- or 5-pair) and shall not interfere with running, tracing, or removing cross-connect wire/patch cables.

Domain: <i>INF Architecture</i>	Number: <i>200.215</i>	Standard Title: <i>Telecommunications Cabling Systems</i>
---	----------------------------------	---

- 7.4.18 All blocks and patch panels will have bases available in 19-inch panels and high-density frame configurations for rack or wall mounting with cable management hardware.
- 7.4.19 All blocks and patch panels will have connecting blocks used for either the termination of cross-connect (jumper) wire or patch cables.
- 7.4.20 All bases and blocks shall be UL Listed 1863, TIA-568, ISO/IEC 11801, and Category 6 compliant and meet TIA Category 6 electrical performance.
- 7.4.21 Fiber optic cables will be terminated on connector panels in a fiber distribution panel.
- 7.4.22 All terminated fibers shall be properly dressed and mounted in rack-mount fiber panels. All fiber panel bulkhead spaces shall contain either connector panels or blank panels.
- 7.4.23 The connector panels shall contain multimode and/or single-mode connector coupling compatible with the SC and LC connectors.
- 7.4.24 All fiber optic cables shall have fusion spliced using factory-polished connectors. Field-terminated connectors are not acceptable.
- 7.4.25 The fiber housing unit shall be configured with fiber patch cable troughs to assist in cable management.
- 7.4.26 Cross-connect fields, patch panels, and active equipment in the TR shall be placed to allow all cross-connections and interconnections via jumpers, patch cables, and equipment cables.
Lengths will not exceed channel specifications:
 - 20 feet per patch cables or jumpers in the horizontal cross-connect
 - 33 feet total for patch cables, jumpers and/or line cables used to connect to the outlet
- 7.4.27 Total channel length should not exceed 328 feet.

7.5 MTR Cabling Support Structures

- 7.5.1 Structures to support the cabling in the MTR are the same as the TR.
- 7.5.2 Basket trays, equipment racks, data equipment cabinets, and wire management troughs shall be used in the room to keep the cabling and equipment organized.
- 7.5.3 Basket tray shall be used to route bulk telecommunications cables within the room.
- 7.5.4 Basket tray shall be at least 12 inches wide and placed under a raised floor or 7 feet above a finished floor to coincide with the top of the equipment racks and cabinets.

AVIATION-SPECIFIC REQUIREMENT FOR SECTION 7.5.4

The basket tray shall be at least 18 inches wide.

- 7.5.5 Basket tray shall provide proper clearance from HVAC ducting or other obstacles.
- 7.5.6 All basket trays shall be bonded and earthed.
- 7.5.7 Separate basket tray shall be used for power pathways to equipment racks.
- 7.5.8 A three-foot working clearance shall be maintained in the front and back of each equipment rack. This clearance shall be measured from the outermost surface of the equipment and connecting hardware rather than from the equipment rack since some of these devices may extend beyond the equipment rack.

Domain: <i>INF Architecture</i>	Number: <i>200.215</i>	Standard Title: <i>Telecommunications Cabling Systems</i>
---	----------------------------------	---

7.6 Cable pathway entrance

- 7.6.1 Sleeves, slots, EZ Paths, and conduits are used to route the cables entering and exiting the room.
- 7.6.2 Sleeves shall have a minimum 2-hour UL listed fire rating and shall be properly fire-stopped in accordance with applicable building codes. All conduits will be fire-stopped in accordance with fire codes as interpreted by the State Fire Marshall Authority Having Jurisdiction (AHJ).
- 7.6.3 A label shall be attached to the wall near each fire penetration stating the UL listed system.
- 7.6.4 Conduit shall be a metallic conduit, 4 inches in diameter.
- 7.6.5 The conduit shall be grounded, equipped with a pull string, and conduit ends will be bushed to protect the cable.
- 7.6.6 EZ Path or approved equivalent shall be used over standard sleeve penetrations through fire-rated walls unless the fire wall is required to be sealed for additional fire suppression requirements.
- 7.6.7 Horizontal sleeves must be sized appropriately to allow for future growth.
- 7.6.8 Vertical sleeves penetrating through the slab shall be a minimum of 4" above and below the finished floor to allow for conduit connectors and bushings.

AVIATION-SPECIFIC REQUIREMENTS FOR SECTION 7.6

- Connection to the MTR and TR shall be via two 4'x4'x12" pull boxes which are located on adjacent walls from each other. Each pullbox will have 2-4" conduits extending into the MTR. All connectivity to the MTR will be via the pullbox with 1" conduits where the cabling will be extended into the MTR using the existing 2-4" conduits.
- Vertical sleeves and slots shall be positioned 6 inches from their center to the wall on which the cables are to be supported. An Arizona state approved Professional Engineer shall approve all structural changes and floor penetrations. Contractor shall acquire approval from the Aviation Technology and Design and Construction Services to position slots and sleeves beyond 6 inches from the wall.
- From the MTR to each TR, a minimum of three 4" pipes are required. This creates a star topology among the MTR to the TR Rooms.
- TRs shall also be connected in a ring topology with a minimum of two 4" pipes.

7.7 Electrical Requirements

- 7.7.1 The rooms shall be equipped with a minimum of two dedicated 120V AC 20 ampere-rated electrical outlets mounted in the bottom of the vertical cable management section on separate branch circuits. The requirement for one of the two dedicated 120V 20-amp circuits is only for powering a stand-alone PDU that serves network equipment. This circuit shall have a NEMA L5-20R twist lock. The other circuit shall be a quad 3-prong receptacle. Outlets are to be located between active equipment racks within the cable management system 12" AFF. For rooms equipped with a whole-room high-capacity UPS, an L5-20R 20 Amp circuit is required at the bottom of the vertical cable management for all networking equipment. Power for subsidiary systems is to be determined by vendor specifications.
- 7.7.2 The number of dedicated and courtesy power outlets shall be determined and approved by the ITS during design.

Domain: <i>INF Architecture</i>	Number: <i>200.215</i>	Standard Title: <i>Telecommunications Cabling Systems</i>
---	----------------------------------	---

- 7.7.3 A minimum of one convenience 120V 20 amperes dedicated quad outlet shall be installed at a designated location 18" AFF for the use of power tools, wet/dry vacuums, laptops, etc.

AVIATION-SPECIFIC REQUIREMENT FOR SECTION 7.7.3

Separate duplex 120V AC convenience outlets (for tools, test sets, etc.) shall also be installed at 18 inches above the finished floor under the electrical subpanel.

7.7.4 Grounding Requirements

- 7.7.4.1 Provide an electrical ground on a 4-inch or larger busbar as defined by Article 250-71(b) in NFPA 70, the National Electrical Code (NEC), for the communications room located near, but not behind, the riser sleeves between floors.
- 7.7.4.2 Connect the grounding bar to a main building ground electrode, complying with the requirements specified in ANSI/J-STD-607-A.
- 7.7.4.3 The hole pattern on the Grounding Bar shall accommodate two-hole lugs per the recommendation of BICSI NECA/BICSI 607-2011 and TIA-607-B standards. Insulators electrically isolate Grounding Bars from the wall or other mounting surfaces, thereby controlling the current path.
- 7.7.4.4 Each TR shall be provided with an electrical ground on a system and building-sized busbar as defined by NEC Article 250.
- 7.7.4.5 Busbars shall be mounted 6 feet 6 inches above the finished floor if a basket tray is included in the design. If the basket tray is not part of the design, busbars shall be located near, but not behind, the backbone sleeves between floors. The Telecommunications Ground Busbar (TGB) shall be sized to accommodate all racking and systems grounding lugs. The TGB shall be required to achieve a maximum resistance reading of 5-ohms. The TGB should be at least 6 mm thick by 50 mm wide.
- 7.7.4.6 This grounding bar shall be connected to a main building ground electrode and shall be common to all TRs.
- 7.7.4.7 All grounding systems shall be provided in the TR and MTR, which shall include but not limited to, cable bonding, cabinet, and relay rack ground kits with #6 THHN wire, ground busses, and ground clamps.

AVIATION-SPECIFIC REQUIREMENTS FOR SECTION 7.7

- The MTR shall be equipped with two (2) separate 200-ampere, 208 volt/120 V, 3 phase, 4-wire electrical panels with service via standby power from the engine-generator distribution network. Each panel should be fed from a separate source using a diverse path. Panels are referred to as Panel A and Panel B in design documents.
- The TR shall have a single 200-ampere, 208 volt/120 V, 3-phase, 4-wire electrical panels with service via standby power from the engine-generator distribution network.

Domain: <i>INF Architecture</i>	Number: <i>200.215</i>	Standard Title: <i>Telecommunications Cabling Systems</i>
---	----------------------------------	---

8.0 Special Systems

- 8.1 Any special system owned and operated by the City of Phoenix that is connected to any City-owned network or telecom service provider via UTP or fiber optic cable shall be governed by this standard as required under A.R. 1.73. This includes CCTV, building automation, card access systems, etc.
- 8.2 Special circuits (i.e., data circuits, T1s, or POTS) shall be cross-connected to designated blocks on the horizontal side.
- 8.3 CATV
 - 8.3.1 A broadband coaxial cable, UTP, or fiber optic cable system shall be installed. When a coaxial system is installed, care shall be taken to ensure the correct cable is used. Cable Distance, RG-6 Quad Shield <=250 feet, RG-11 <=400 feet.
 - 8.3.2 ITS shall determine the method of serving City facilities for CATV. Methods may include but are not limited to an entrance cable from Cox, other service providers, or City-owned video distribution equipment.
 - 8.3.3 All services, cabling, and equipment shall be ordered through ITS.
- 8.4 Carrier-Owned Distributed Antenna System (DAS)
 - 8.4.1 Carrier DAS shall be approved by the Real Estate Department prior to installation.
 - 8.4.2 All in-building pathways shall be furnished and installed by the carrier.
 - 8.4.3 Use of all underground conduit infrastructure from the property line into the MTR shall be reviewed and approved by ITS prior to installation.
 - 8.4.4 A pre-construction conference is required for all projects. The carrier shall notify ITS 10 days in advance.
 - 8.4.5 Design and placement of equipment within COP-owned communications room shall be coordinated and approved by ITS.
 - 8.4.6 Final inspection and acceptance shall be completed by the ITS radio shop.
- 8.5 700 MHz Public Life Safety Radio System
 - 8.5.1 Coordinate with ITS for use of basket tray to house the conductors for monitoring dry contacts.
 - 8.5.2 Coordinate with ITS for use of outside of basket tray to support the heliax coax cables that connect antennas to the amplifiers.
 - 8.5.3 Design and placement of equipment within COP-owned communications room shall be coordinated and approved by ITS.
- 8.6 Fire Alarm System
 - 8.6.1 Fire Alarm Control Panels (FACP) shall be cabled with a Dual Drop as required by Public Works Department or Aviation Facilities for network monitoring.
 - 8.6.2 FACP communications to downtown Central Monitoring Systems shall be designed and coordinated by ITS. Methods include traditional analog telephone service or other wireless technologies.

Domain: <i>INF Architecture</i>	Number: <i>200.215</i>	Standard Title: <i>Telecommunications Cabling Systems</i>
---	----------------------------------	---

AVIATION-SPECIFIC REQUIREMENTS FOR SECTION 8.6

- The Aviation Fire Alarm System communicates on a discreet City of Phoenix network that maintains a UL Listing. For specifications on the current FACP communication cabling requirements, coordinate with Facilities, ITS, and Fire Alarm System Design team.
- Coordination between the contractor and Aviation Technology shall be performed for fiber optic cross-connectivity within the Aviation TRs.

8.7 Closed Circuit Television (CCTV)

8.7.1 A single building administered outlet shall be installed for each camera.

8.7.2 The category cable shall be specified by ITS and installed by ITS per A.R. 1.73. The UTP cable may consist of plenum category 6, OSP category 6, Game Changer, or approved equivalent.

8.7.3 Coordination between the contractor and the ITS shall be required for all required connectivity within the TRs.

8.8 Building Management Systems (BMS)

8.8.1 Coordination between the contractor and ITS shall be required for all connectivity within the TRs.

8.8.2 If a connection to the enterprise network is required, each device will receive a dual drop.

8.9 Fuel Force

8.9.1 Coordination between the contractor and ITS shall be required for all connectivity within the TRs.

8.9.2 If a connection to the enterprise network is required, each device will receive a dual drop.

8.10 Heating, Ventilation and Air Conditioning (HVAC)

8.10.1 Coordination between the contractor and ITS shall be required for all connectivity within the TRs.

8.10.2 If a connection to the enterprise network is required, each device will receive a dual drop.

8.11 Lighting Control

8.11.1 Coordination between the contractor and ITS shall be required for all connectivity within the TRs.

8.11.2 If a connection to the enterprise network is required, each device will receive a dual drop.

8.12 Electric Power Meter (EPM)

8.12.1 Coordination between the contractor and ITS shall be required for all connectivity within the TRs.

8.12.2 If a connection to the enterprise network is required, each device will receive a dual drop.

Domain: <i>INF Architecture</i>	Number: <i>200.215</i>	Standard Title: <i>Telecommunications Cabling Systems</i>
---	----------------------------------	---

8.13 Parking Revenue Control Systems

- 8.13.1 Coordination between the contractor and ITS shall be required for all connectivity within the TRs.
- 8.13.2 If a connection to the enterprise network is required, each device will receive a dual user-administered outlet.
- 8.13.3 ITS shall be responsible for designing and installing any horizontal or backbone cabling needed for service provider circuit extensions or connectivity to other City facilities.

8.14 Elevator Monitoring

- 8.14.1 Coordination between the contractor and ITS shall be required for all connectivity within the TRs for all elevator communications.
- 8.14.2 If a connection to the enterprise network is required, each device will receive a dual drop.
- 8.14.3 All dial tones for call boxes shall be provided by ITS.

8.15 Water Services Process Control Network

- 8.15.1 All fiber optic infrastructure projects related to WSD PCN on campus at water plants shall be reviewed and approved by ITS during the design phase.
- 8.15.2 ITS shall review and approve all product submittals.
- 8.15.3 ITS shall conduct periodic quality control inspections during the installation phase of each project.
- 8.15.4 ITS shall conduct final inspections for acceptance at project completion.

8.16 Outdoor Marquee's and Roadway Digital Messaging Boards

- 8.16.1 Coordination between the contractor and ITS shall be required for all connectivity within the MTRs, TRs, and outdoor cabinets.
- 8.16.2 If a connection to the enterprise network is required, each device will receive a dual user-administered outlet.
- 8.16.3 ITS shall be responsible for designing and installing any horizontal or backbone cabling needed for service provider circuit extensions or connectivity to other City facilities.

8.17 Access Control System

- 8.17.1 Coordination between the contractor and ITS shall be required for all connectivity within the TRs.
- 8.17.2 Each device will receive a dual drop installed by ITS.

8.18 Paging System

- 8.18.1 ITS shall be included in design review and installation quality control inspections during installation.
- 8.18.2 Systems are typically installed by others.
- 8.18.3 Dial tone and telephone system integration shall be provided by ITS.

8.19 Emergency Phones

- 8.19.1 Coordination between the contractor and ITS shall be required for all connectivity within the TRs.
- 8.19.2 Each device will receive a dual drop installed by ITS.

Domain: <i>INF Architecture</i>	Number: <i>200.215</i>	Standard Title: <i>Telecommunications Cabling Systems</i>
---	----------------------------------	---

8.19.3 Devices are owned and maintained by the Department, all cabling and dial tone is provided by ITS.

8.20 Street Transportation Intelligent Transportation Systems Network

8.20.1 All fiber optic infrastructure projects related to the Intelligent Transportation Systems Network shall be reviewed and approved by ITS during the design phase.

8.20.2 ITS shall review and approve all product submittals.

8.20.3 ITS shall review and approve all Requests for Information during the construction phase.

8.20.4 ITS shall conduct periodic quality control inspections during the construction phase of each project.

8.20.5 ITS shall conduct final inspections for acceptance at project completion.

8.20.6 All traffic cabinet fiber optic termination hardware shall be breakaway connectors using SC or LC connectors as specified by ITS.

8.21 Fire Station Alerting System (CAD)

8.21.1 ITS shall be responsible for furnishing and installing all UTP cabling for this system. When installation is needed on an active system, Fire Technical Services staff shall be notified to provide approval and escort as required. All UTP cabling for this system shall have a white jacket.

8.21.2 All speaker cabling for this system shall have a gray jacket.

8.21.3 Design, ownership, and maintenance of all components and hardware is the responsibility of Fire Technical Services.

8.21.4 For further details on specifications for the system, refer to Phoenix Fire Standard 17200 Fire Station Dispatch Infrastructure.

8.22 Future Systems

8.22.1 All future systems shall not utilize the enterprise network for connectivity unless otherwise approved by ITS.

8.22.2 Any category cables that are used as conductors for signaling/communications outside of the structured cabling system that are installed and managed by the City of Phoenix shall use a cable color other than BLUE. Blue category cable is reserved for use by the City of Phoenix. These cables shall not terminate in the TR or MTR. For more information, refer to Table 5.

AVIATION-SPECIFIC REQUIREMENTS FOR SECTION 8.22

- Access Control (ACAMS)/Power Over Ethernet (POE) Locks.
- TR space allocation must be coordinated with ITS.
- Basket tray can be shared with ACAMS wiring so long as a divider is used for separation.
- Coordination between the contractor and Aviation Technology shall be required for all required connectivity within the TRs.
- Refer to the responsibility matrix below for details on POE lock installation.

Domain: INF Architecture	Number: 200.215	Standard Title: Telecommunications Cabling Systems
------------------------------------	---------------------------	--

Action Item	Responsible Party
Provide Conduit to Cable Demarcation box above the door	Contractor
Provide Conduit for Door Frame	Contractor
Provide EPT	Contractor
Providing Frame Harness Cable	Contractor
Providing Door Harness Cable	Contractor
Installing Cable Harnesses	Contractor
Provide category cable to box above door	AVN Tech
Installing Cable Connectors on Door Harness	Contractor
Installing E-Lock in the Door	Contractor
Commissioning E Lock	Contractor (via Honeywell)

Table 5

8.23 Passenger Emergency Duress System (PEDS)

8.23.1 Coordination between the contractor and Aviation Technology shall be required for all connectivity within the TRs.

8.24 Public Address System (PAS)

8.24.1 Paging cabinet to allow space for 48 port patch cable that is used for tie cables to the City of Phoenix cabling rack.

8.24.2 Speaker cabling for the PAS system can utilize City of Phoenix basket tray within the MTR and TR so long as a minimum of 12 inches of separation is maintained between other system cabling.

8.24.3 Cables will be neatly bundled within the basket tray.

8.24.4 Coordination between the contractor and Aviation Technology shall be required for all required connectivity within the TRs

8.24.5 When the PAS System is used to meet Fire Life Safety code, the conduit and shall meet all survivability requirements.

8.25 Audio Frequency Induction Loop

8.25.1 Hearing Loop cabling for the PAS system can utilize City of Phoenix basket tray within the MTR and TR so long as a minimum of 12 inches of separation is maintained between other system cabling.

8.25.2 Cables will be neatly bundled within the basket tray.

8.25.3 Coordination between the contractor and Aviation Technology shall be required for all required connectivity within the TRs.

8.26 Common Use Passenger Processing System (CUPPS)

8.26.1 Coordination between the contractor and Aviation Technology shall be required for all connectivity within the TRs.

8.27 Electronic Video Information Display Systems (EVIDS)

8.27.1 Coordination between the contractor and Aviation Technology shall be required for all connectivity within the TRs.

Domain: <i>INF Architecture</i>	Number: <i>200.215</i>	Standard Title: <i>Telecommunications Cabling Systems</i>
---	----------------------------------	---

8.28 Passenger Boarding Bridges (PBBs)

8.28.1 Specifications must be approved by ITS prior to installation.

8.28.2 Traveler cables must be UL Listed.

8.28.3 Preinstalled category cables shall be terminated, and test results shall be submitted prior to system commissioning.

8.29 Baggage Handling Systems (BHS)

8.29.1 Coordination between the contractor and Aviation Technology shall be required for all connectivity within the TRs.

8.30 Emergency Fuel Shut Off (EFSO)

8.30.1 Coordination between the contractor and Aviation Technology shall be required for all connectivity within the TRs.

9.0 Infrastructure Documentation

The purpose of this section is to define a set of guidelines for collecting documentation related to all cabling system projects within the City of Phoenix. These policies set the minimum requirements for all documentation that is received by contractors, architects, or any design professional involved in the installation of telecommunications infrastructure. Following these guidelines will ensure that all documentation that is associated with cabling system projects will fit the criteria for entry into the City of Phoenix cable management system, including spatial and non-spatial elements. These guidelines will also ensure that future cabling projects will utilize existing and accurate documentation to design and place new infrastructure. The City of Phoenix reserves the right to revise these guidelines if industry standards or business/operational requires change.

The final acceptance of documentation for all projects is at the discretion of the communications engineer, project coordinators, or City personnel responsible for the management of cabling system projects. Any alternatives or recommendations relating to a specific cabling project should be presented to City personnel and will be considered on an individual basis. The acceptance of any documentation that deviates from these guidelines will be considered an exception and shall not set a precedence for future submittals. ITS is responsible for supervising and finalizing all documentation related to all cabling system projects.

9.1 Inside Plant Documentation

9.1.1 ITS will review and sign off on as-builts for workstation locations and labeling scheme. It is the contractor's responsibility to acquire the most current floorplans and or site plans for the purpose of labeling workstation locations. As-builts should include the entire floor/building involved. As-builts containing only a portion of floorplan/building and not the entire footprint will not be accepted.

9.1.2 ITS will develop the labeling schemes for the telecom rooms, intra-building backbone, patch panels, fiber distribution panels, or telecommunications termination blocks.

9.1.3 ITS will create or acquire location codes for all buildings related to cabling projects and provide them to the contractor for inclusion into the labeling scheme.

9.1.4 Contractor shall create as-builts for workstation location and cable numbering using the approved labeling scheme. All effort will be made by City personnel to acquire electronic as-builts, but it is the contractor's responsibility to acquire these documents

Domain: <i>INF Architecture</i>	Number: <i>200.215</i>	Standard Title: <i>Telecommunications Cabling Systems</i>
---	----------------------------------	---

for the purpose of labeling workstation locations. As-builts shall include the entire floor/building involved. As-builts containing only portion of floorplan/building and not the entire footprint will not be accepted.

- 9.1.5 Contractor shall comply with TR and MTR labeling scheme, including telecom room directional acronym. Contractor will supply a placard in each MTR and TR that currently does not have one. The placard should include the SAP location code and the floor and directional acronym. See [Figure #9](#) for more information.
 - 9.1.6 Contractor shall comply with intra-building backbone labeling scheme. The City of Phoenix defines intra-building backbone as house copper cable (HC) or house fiber cable (HF). All newly placed cables should have approved cable tags attached. See [Figure #10](#) for more information.
 - 9.1.7 Contractor shall comply with labeling scheme for all patch panels, fiber distribution panels or telecommunications termination blocks. All three types of hardware should be labeled with the appropriate HC or HF labeling scheme accepted by City personnel.
 - 9.1.8 Contractors shall utilize SAP location codes on all buildings related to cabling projects. Location codes will be provided to contractor for the inclusion into labeling scheme. Contractor shall correct any documentation and labeling discrepancies as required by ITS.
- 9.2 Outside Plant Documentation
- 9.2.1 As-builts must be completed by the contractor in AutoCAD Version 2018 or newer, as well as Adobe PDF. Identification of all newly placed or modified infrastructure is required. If as-builts are not geo-referenced (to scale or matched to a known coordinate system), a minimum level of surveying shall be completed. The acceptable level of surveying includes wheeled measurements of all segments of conduit and offset dimensions from a known location (street centerline, building, etc.). Exceptions to this standard will be considered if no known location exists. All requests for an exception to the standard should be submitted to City personnel.
 - 9.2.2 Documentation is required for all contents of conduit systems. This includes, but is not limited to, copper cable, fiber optic cable, coaxial cable, inner duct, flexible inner duct (MaxCell), and detectable tracer wire. Included in this standard is the documentation of all newly placed cables. A reasonable number of specifications is expected (make, manufacturer, size, diameter, serial number, etc.). Verify with ITS for any additionally required specifications.
 - 9.2.3 Contractor shall comply with inter-building backbone labeling scheme. The City of Phoenix defines inter-building backbone as remote copper cable (RC) or remote fiber cable (RF). All newly placed cables should have approved cable tags attached. A cable tag label should be placed in every manhole, hand hole, pull box or pull point. See [Figure #11](#) for more information.
 - 9.2.4 Contractor shall comply with the labeling scheme for all patch panels, fiber distribution panels or telecommunications termination blocks. All three types of hardware should be labeled with the appropriate RC or RF labeling scheme.
 - 9.2.5 Contractor is responsible for the creation or modification of manhole fold flats. Fold flats are required for any manhole that has new or modified infrastructure added. ITS is responsible for providing to the contractor any existing fold flat for manholes in the project area. See [Figure #6](#) for more information.

Domain: <i>INF Architecture</i>	Number: <i>200.215</i>	Standard Title: <i>Telecommunications Cabling Systems</i>
---	----------------------------------	---

- 9.2.6 Contractor is responsible for creation of splice details. Any newly placed or existing copper cable or fiber optic cable that is spliced shall be documented. See [Figure #8](#) for more information.
- 9.2.7 These detailed drawings are required for any structure that is part of the project scope of work. Maintenance Hole and Hand Hole AutoCAD drawings shall include the following layout tabs: cover sheet, butterfly, photo, and (if applicable) splice detail. Each AutoCAD drawing file shall depict ONLY one communication space structure.
- 9.2.8 The project cover sheet layout shall be the first layout tab of the AutoCAD detailed drawing file. See [Figure #5](#) for more information.
 - 9.2.8.1 Project information must include the project name, address and location, City of Phoenix-ITS work order number, and date.
 - 9.2.8.2 Contractor information must include company information using the provided text field in the upper right-hand corner of the layout.
 - 9.2.8.3 The Vicinity map accurately represent project area with a leader line.
 - 9.2.8.4 The sheet index provides an enumerated list of all project sheets with their corresponding file names and a brief description (i.e., "MH/HH & Photo").
 - 9.2.8.5 The Project area map provides a scaled base map (i.e., parcels, street centerlines, street names, curbs, or other surveyed data) of the complete project area of work. Contractor shall indicate all conduit pathway lines and communication space within the scope of work with their respective annotation. Contractor shall label the location of each communication space with the asset identification number that corresponds to the detailed drawing file.
 - 9.2.8.6 All base map data provided to and from City of Phoenix ITS shall be georeferenced in the NAD 1983 Arizona State Plane (HARN) international feet coordinate system. The contracting company shall not move, scale, or otherwise modify the base map drawings, such that the integrity of the data is preserved.
- 9.2.9 The fold flat layout shall be the second layout tab of the AutoCAD detailed drawing file. See [Figure #6](#) for more information.
 - 9.2.9.1 The butterfly layout is intended to represent the infrastructure exactly as it appears in the field including conduit placement, new and existing cables, innerduct/sub duct, splice cases, etc. Label each wall of the butterfly drawing with the most appropriate compass point (i.e., North, South, East, or West).
 - 9.2.9.2 Every conduit in or out of the communication space shall be represented on the corresponding face of the butterfly drawing. Label empty conduits with an "E" in the center of the conduit symbol. All conduits containing infrastructure shall be annotated with an individualized summary of their contents. All conduit leader annotation shall begin with the conduit length and name of the destination structure. i.e., "517 feet to MH-105", "844 feet to Fire Station 62", "12 feet to traffic cabinet NW corner". All conduits may or may not lead toward the same destination. Annotate all exceptions individually in accordance with the annotation convention. This conduit length annotation requirement may only apply to projects that contain the

Domain: <i>INF Architecture</i>	Number: <i>200.215</i>	Standard Title: <i>Telecommunications Cabling Systems</i>
---	----------------------------------	---

installation of new conduit or new cable within conduit. Acceptable methods of gathering this information may include the use of sequential cable footage markings or calibrated mule tape. Verify with ITS.

- 9.2.9.3 The details section provides specific detailed information regarding the associated object. Each individual cable or inner duct, splice closure, etc., shall have a detailed summary leader in the layout section with a corresponding description in the details section. If the object is a cable, it shall be completed with cable count, cable manufacturer, cable type, cable footage readings, cable coil length, and cable install date. Every cable detail record shall have two sequence footage entries. Indicate the cable sequence number where the cable enters/exits the communication space at a conduit or where the cable enters/exits a splice closure.
- 9.2.9.4 If the object is an innerduct/sub duct, it shall be completed with quantity, size, and description. If any attribute is unknown, do not leave the detail field blank. Fill out the field detail with either "Unknown" or "UNK". For splice closures, include the manufacturer name and model number.
- 9.2.9.5 An example of a fiber object would be: "144 ST Corning SM; East Wall: 2768', West Wall: UNK (Unreadable), Coil: UNK; Installed 5/14/2022"
- 9.2.9.6 The title block - CITY OF PHOENIX-ITS area shall not be modified.
- 9.2.9.7 The title block location map area shall illustrate the immediate area surrounding the communication space drawing or the area surrounding the pathway detail drawing. This area shall be a viewport to the base map in model space.
- 9.2.9.8 The title block location information area shall be completed with project detail information that is relative to the respective infrastructure.
- 9.2.9.9 First line attribute is the specific infrastructure identification and shall include the manhole, handhole, or pull box description (i.e., MH-1901 or HH-1001 or PB-0501).
- 9.2.9.10 The second line attribute is the address or intersection of the infrastructure (i.e., 1901 S. 24th Street or SW corner of 5th Street & Adams Street).
- 9.2.9.11 The Third line attribute shall reflect the spatial coordinates of the infrastructure in the NAD 1983 Arizona State Plane (HARN) coordinate system or WGS 1984 coordinates (decimal degrees).
- 9.2.9.12 The Fourth line attribute (photo sheet only) is the photo x-references being used and shall be completed as: i.e., MH-1901-001, MH-1901-002, MH-1901-003, MH-1901-004, MH-1901-005.
- 9.2.9.13 The fifth line attribute (Splice case detail only) is the detail number designated on the fold flat sheet and shall include the description.
- 9.2.10 Photo layout shall be the third layout tab of the AutoCAD detailed drawing file. See [Figure #7](#) for more information.
- 9.2.10.1 Photos shall be externally referenced using relative pathing such that the photo is visible within the drawing regardless of the location of the AutoCAD drawing file.

Domain: <i>INF Architecture</i>	Number: <i>200.215</i>	Standard Title: <i>Telecommunications Cabling Systems</i>
---	----------------------------------	---

- 9.2.10.2 Place all photos, logos, and any other externally referenced drawings in an accompanying folder named "Xref."
- 9.2.10.3 Photos shall be clear and free of distortion and be taken with a minimum 5.0 mega pixel digital camera at minimum resolution of 1600x1200.
- 9.2.10.4 Photos shall be taken facing the north wall of the structure such that the orientation of the photograph matches the orientation of the butterfly drawing.
- 9.2.10.5 Photos shall have a visible date stamp that is accurate and generated by the digital camera at the time the photo was taken.
- 9.2.10.6 If the maintenance hole is greater than a no. 9 (4'x4'), there shall be (4) photos taken, (1) of each wall without a fisheye lens. (1) Additional photo shall be taken from the street level looking down at the open communication space, facing north with no obstructions. This total number of photos equals (5) per manhole. The photos shall be placed on the layout representative to the butterfly layout depiction, i.e., the photo facing north should be placed on the north side of the photo layout and the photo facing south should be placed on the south side of the photo layout etc. The photo taken from the street level shall be placed in the middle with all photos scaled to be the same.
- 9.2.10.7 If the communication space is less than 4'x4', only (1) photo shall be taken from street level looking down at the open communication space, facing north with no obstructions. All walls and conduits shall be visible in the photo.
- 9.2.10.8 The splice detail layout (if applicable) – Shall be the fourth layout tab of the AutoCAD detailed drawing file. See [Figure #5](#) for more information.
- 9.2.11 The splice detail layout is intended to graphically depict detailed information regarding the splicing and connectivity of all fiber cables within a specific splice closure. Attention to detail is critical. See [Figure #8](#) for more information.
- 9.2.11.1 Only one splice closure shall be depicted in any given splice detail layout tab. If the communication space contains multiple splice closures, each splice closure shall have its own unique splice detail layout tab. If the scope of work contains multiple splice closures at multiple locations, then each location shall have an individual and separate drawing file depicting the infrastructure at that specific location.
- 9.2.11.2 All cables entering the splice closure shall have a cable identification tag. The cable identification tag annotation text shall reference the corresponding detail ID letter on the butterfly layout tab as well as the destination location of the cable. The cable label fields on the identification tag shall be completely filled in with the cable manufacturer, the cable strand count, and the date of installation. All buffer tubes and strands from all cables entering the splice closure shall be accounted for in the splice detail diagram (i.e., spliced through, or dark).
- 9.2.12 The pathway detail drawing file shall be a separate AutoCAD drawing file. Pathway detail drawings are intended to depict the location of underground conduit pathways and communication spaces. Documentation for underground conduit

Domain: <i>INF Architecture</i>	Number: <i>200.215</i>	Standard Title: <i>Telecommunications Cabling Systems</i>
---	----------------------------------	---

pathways must reflect the “real world” location of the infrastructure. A high degree of spatial accuracy is vital, and all drawings must be to scale and in units of feet. The AutoCAD drawing file shall include the following layout tabs: cover sheet and pathway. See [Figure #12](#) for more information.

9.2.12.1 Line work drawn upon aerial imagery in Google Earth is not an acceptable form of documentation for right of way conduit pathways. “Not to scale” or representational drawings are also not acceptable forms of documentation for right of way conduit pathways. Line work drawn upon aerial imagery may be acceptable for smaller campus environments where the work is not being performed in the City of Phoenix right of way.

9.2.13 ITS will review and sign off as-builts. If as-builts are not geo-referenced, a minimum level of surveying will be completed by the contractor. The acceptable level of surveying includes wheeled measurements of all segments of conduit, offset dimensions from a known location (e.g., street centerline, building).

10.0 Quality Assurance

This section addresses requirements for Quality Assurance for all aspects of the Standard. Contractor Qualifications:

- 10.1 Only City approved vendors shall be used to perform any installation or services.
- 10.2 Shall be certified to install and warrant the Ortronics Structured Cabling System or approved equivalent.
- 10.3 Shall be certified as listed in the Corning Network of Preferred Installer to install and warrant the Cabling System or approved equivalent.
- 10.4 Shall have a BICSI RCDD (Registered Cabling Distribution Designer) under current employment and available for consultation on all projects. Shall demonstrate knowledge and compliance with all BICSI, TIA, UL, and NEC standards and codes.
- 10.5 Contractor shall have the required number of certified installers as mandated by the manufacturer as having completed the necessary training to complete the installation. Resumes of the certified members on the team shall be provided along with documentation of completed training courses.

11.0 Systems Warranty

This section addresses the requirements for obtaining the required warranty coverage for all City of Phoenix projects upon installation completion.

- 11.1 The cabling installation shall be installed such that it qualifies for the manufacturer’s System Installation warranty. A Structured Cabling System means a System properly constructed with ITS-approved products in accordance with referenced standards, meeting specified link/channel performance and topological (distance and connection) limits. This includes all Manufacturers’ products that are installed in conjunction with approved solutions. Performance guarantees apply only to installed channels utilizing appropriate patch cords manufactured from partner cable manufacturers’ cordage. Any warranty repairs, replacements, moves, additions, or changes shall be warranted for the balance of this warranty period.
- 11.2 Warranty shall commence on the date of installation registration which shall coincide with installation completion.

Domain: <i>INF Architecture</i>	Number: <i>200.215</i>	Standard Title: <i>Telecommunications Cabling Systems</i>
---	----------------------------------	---

- 11.3 The Warranty shall ensure that the installation:
 - 11.3.1 Will be free from Bit errors caused by the structured cabling system components.
 - 11.3.2 Will meet or exceed applicable ratified TIA and ISO/IEC transmission performance standards in force at the time of installation for a Structured Cabling Link/Channel.
 - 11.3.3 Will support any current or future application which is designed for transmission over a Structured Cabling System as defined by the above-referenced standards and the Data Sheet in effect at the time of installation.
 - 11.3.4 Will conform to the transmission performance specifications of the Data Sheet in effect at the time of installation.
 - 11.3.5 Will be free from defects in material and workmanship on the products installed.
- 11.4 Warranty Conditions for this warranty to be valid:
 - 11.4.1 The System components that have never been used.
 - 11.4.2 The System shall have been installed by a Certified Integrator/Installer authorized by the Manufacturer in accordance with the Manufacturer's installation specifications, the requirements of the above-mentioned technical standards, and the terms and conditions specified in the manufacturer's Certified Integrator/Installer Program agreement.
 - 11.4.3 All installation records shall be updated to reflect any maintenance, movements, additions, or changes, etc. Manufacturer will not be responsible for moves, additions or changes performed by parties other than a Certified Integrator/Installer.

V. RELATED POLICIES, STANDARDS, AND PROCEDURES

TIA-568: Commercial Building Telecommunications Cabling Standard
 TIA-569: Commercial Building Standard for Telecommunications Pathways and Spaces
 TIA-606: The Administration Standard for the Telecommunications infrastructure of Commercial Building
 TIA-607: Commercial Building Bonding and Grounding (Earthing) Requirements for Telecommunications
 TIA-758: Customer Owned Outside Plant Telecommunications Infrastructure Standard
 TIA-527: Optical Power Loss Measurements of Installed Single-mode Fiber Cable Plant – OFSTP-7
 TIA-526-14-A: Optical Power Loss Measurements of Installed Multimode Fiber Cable Plant-OFSTP-14A.
 TIA-598: Optical Fiber Cable Color Coding (January 2005).
 TIA-942: Telecommunications Infrastructure Standard for Data Centers
 BICSI-TDMM, Building Industries Consulting Services International, Telecommunications Distribution Methods Manual
 Fire stopping Systems - American Society for Testing and Materials (ASTM) E814, Underwriters Laboratories Inc. (UL) 1479
 National Electrical Code
 National Fire Protection Association 75 and 76
 City of Phoenix Codes, Ordinances, Standards, and Interpretations
 A.R. 1.73, Control of Communications Services and Systems
 Phoenix Fire Standard 17200 Fire Station Dispatch Infrastructure
 b1.3 IT Waiver Standard

Domain: <i>INF Architecture</i>	Number: <i>200.215</i>	Standard Title: <i>Telecommunications Cabling Systems</i>
---	----------------------------------	---

VI. QUESTIONS

Questions regarding this policy should be directed the DCIO of Enterprise Telecommunications Services.

This Policy has been approved.

By: Assistant Chief Information Officer, Business Operations

Tom Magrin

February 2, 2023
Date

VII. REVISION HISTORY

Version	Date	Detail of Changes
3.0	2/2/2023	BICSI updates, Aviation Supplement incorporated, Fire Technical Services section.
2.0	12/28/2016	BICSI updates.
1.0	11/1/2001	Original Approved Standard

Domain: <i>INF Architecture</i>	Number: <i>200.215</i>	Standard Title: <i>Telecommunications Cabling Systems</i>
---	----------------------------------	---

VIII. ATTACHMENTS/IMAGES

Trench Detail

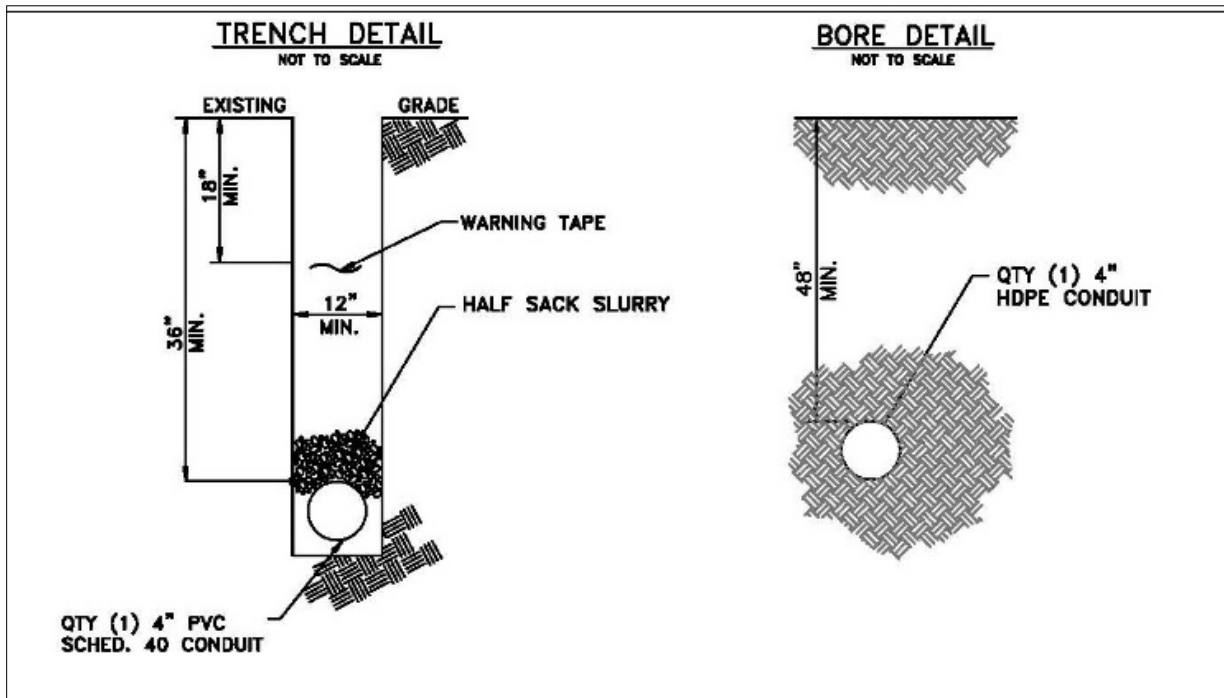

Figure 1

Manhole and Handhole Requirements

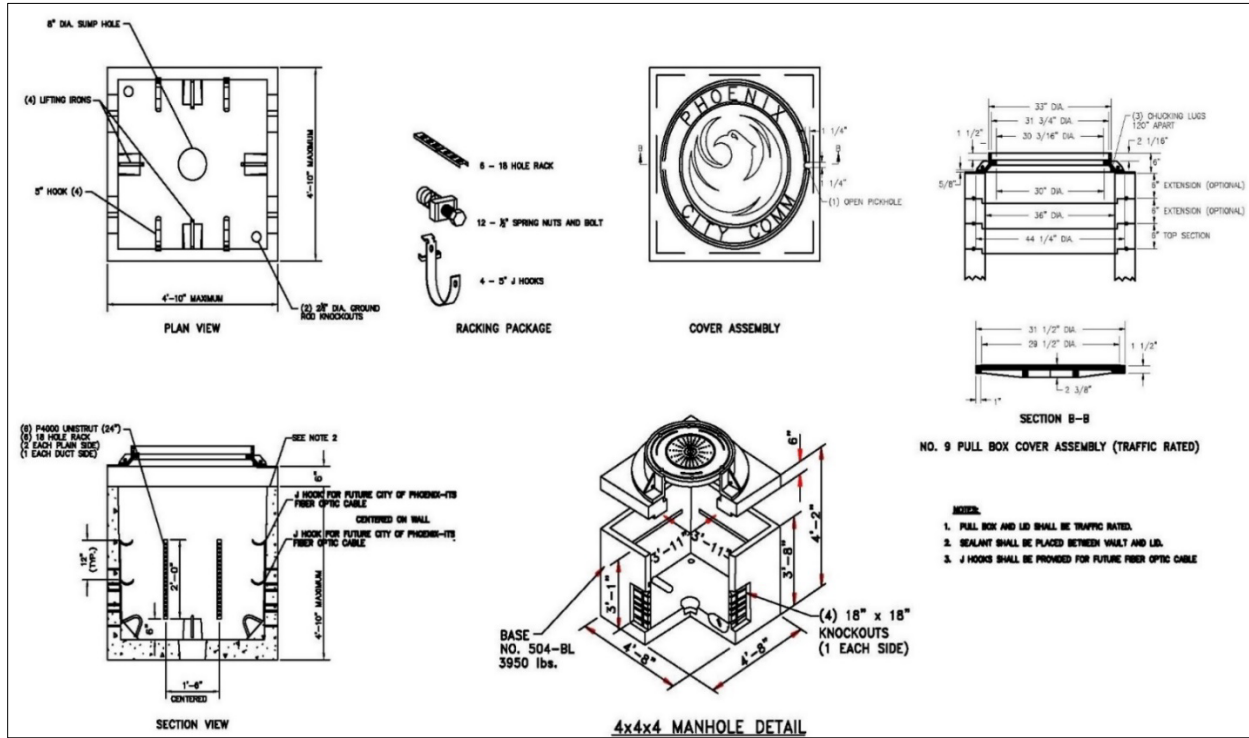

Figure 2

Domain: INF Architecture	Number: 200.215	Standard Title: Telecommunications Cabling Systems
------------------------------------	---------------------------	--

"CITY COM" Lid

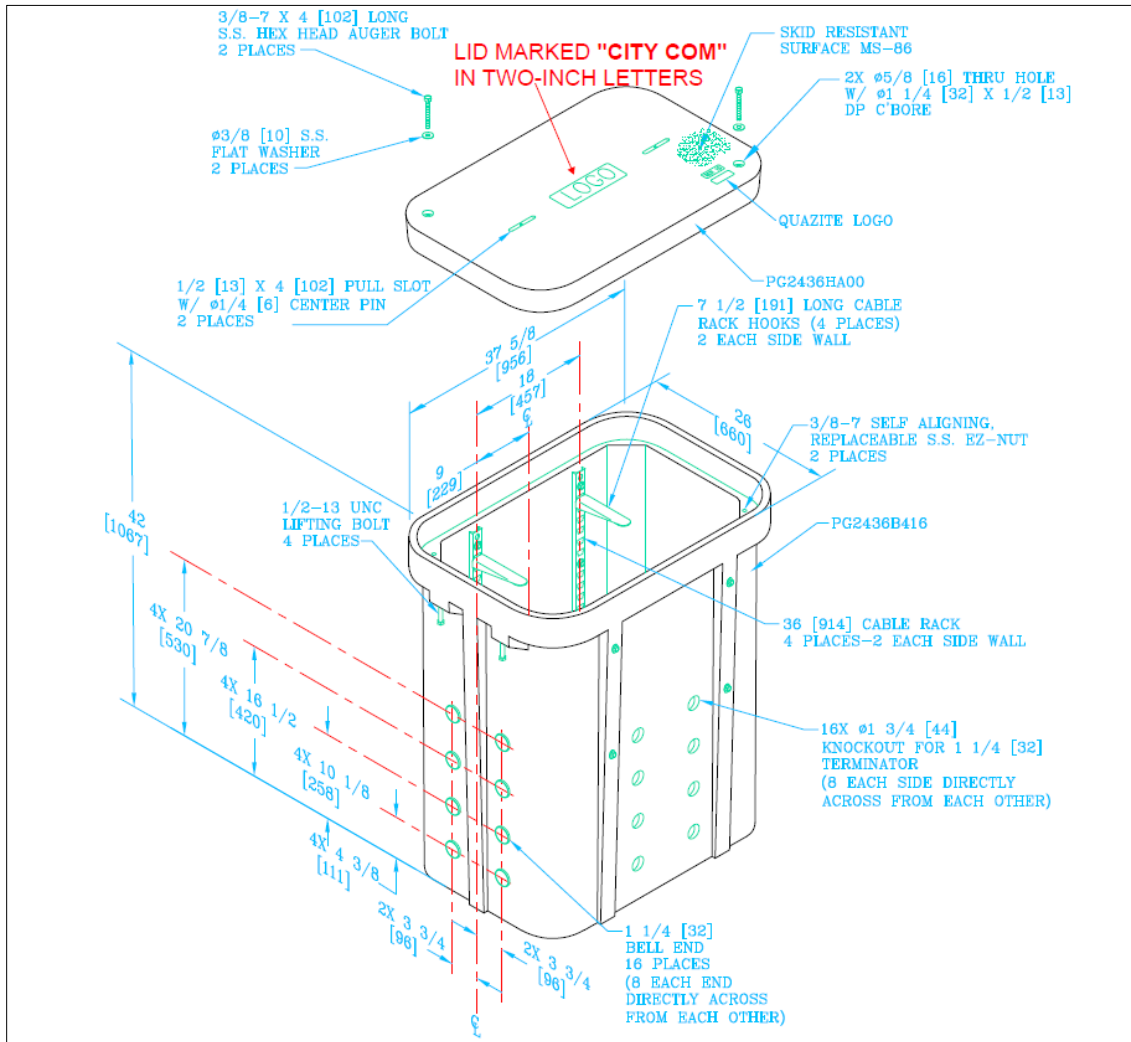

Figure 3

Domain: INF Architecture	Number: 200.215	Standard Title: Telecommunications Cabling Systems
------------------------------------	---------------------------	--

Aircraft-rated Lids

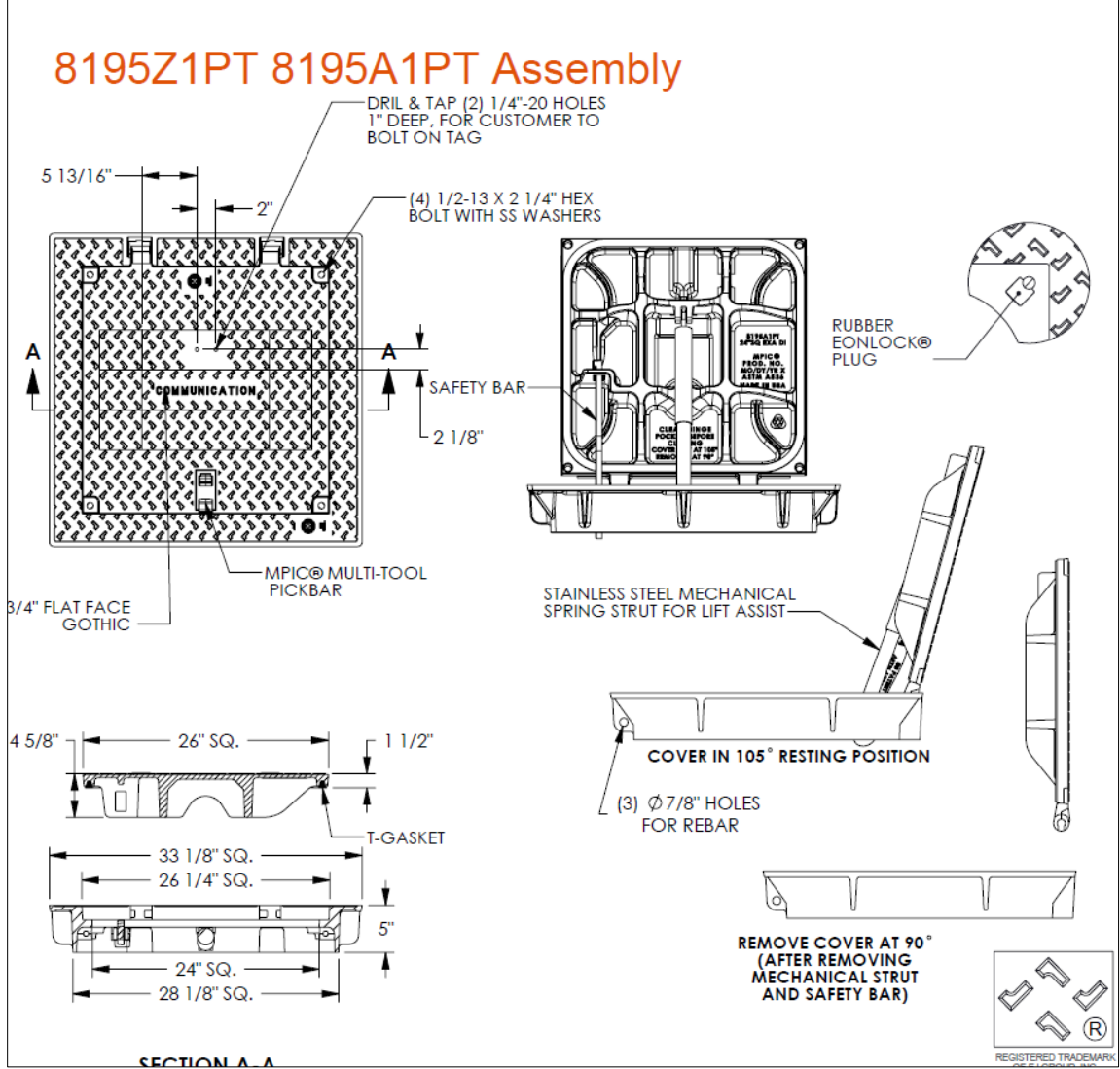

Figure 4

Domain:
INF Architecture

Number:
200.215

Standard Title:
Telecommunications Cabling Systems

AutoCAD



<p>CONTRACTOR INFORMATION</p> <p>LOGO (DELETE ME)</p> <p>ADDRESS LINE 1 ADDRESS LINE 2 C: (###) ###-#### F: (###) ###-#### WEB SITE</p>  <p>VICINITY MAP SCALE: NTS</p>	<p>CITY OF PHOENIX INFORMATION TECHNOLOGY SERVICES UNIFIED COMMUNICATIONS</p> <p>PROJECT NAME PROJECT LOCATION WORK ORDER # DATE:</p>  <p>SHEET INDEX</p> <p>COVER SHEET MH-XX: FOLD FLAT AND PHOTOS MH-XX: FOLD FLAT, PHOTOS, AND SPLICE DETAIL</p> <p>PROJECT AREA MAP</p>
--	---

Figure 5

Domain: INF Architecture	Number: 200.215	Standard Title: Telecommunications Cabling Systems
------------------------------------	---------------------------	--

AutoCAD Fold Flat

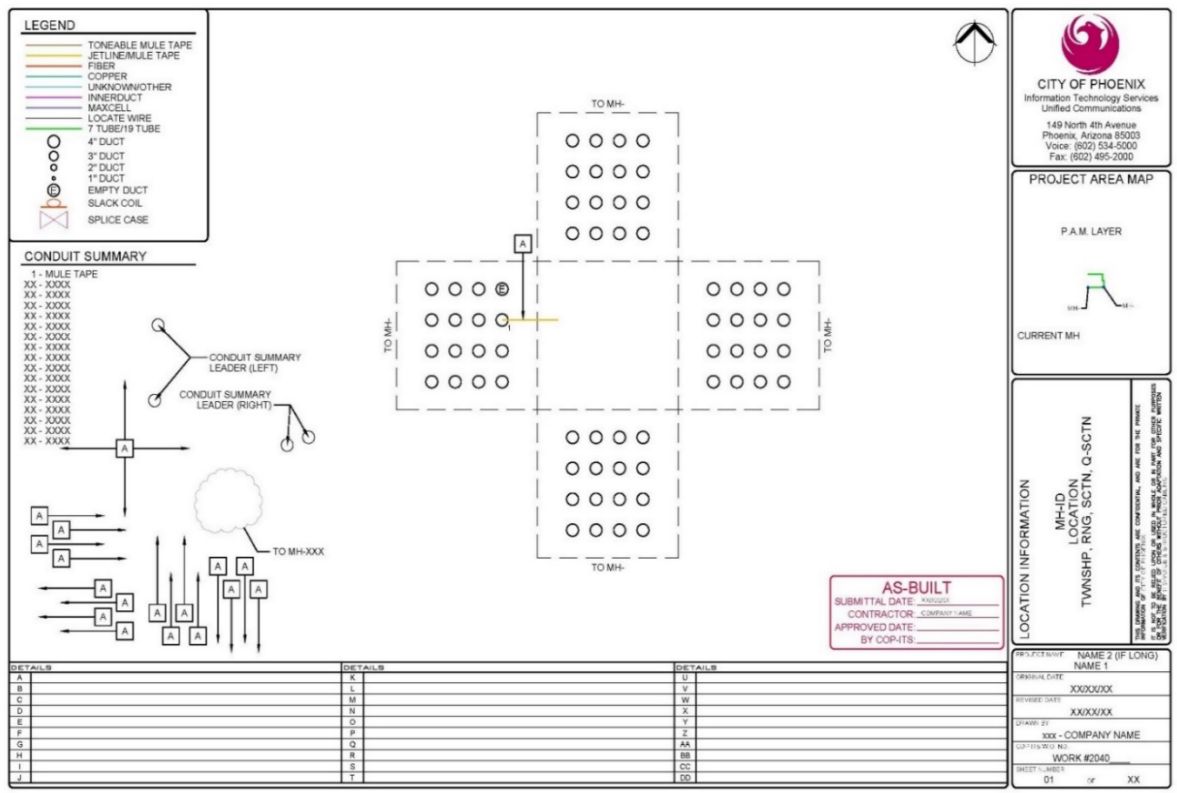

Figure 6

Domain: INF Architecture	Number: 200.215	Standard Title: Telecommunications Cabling Systems
------------------------------------	---------------------------	--

AutoCAD Top View

TOP VIEW

CITY OF PHOENIX
Information Technology Services
Unified Communications
149 North 4th Avenue
Phoenix, Arizona 85003
Voice: (602) 534-5000
Fax: (602) 496-2000

PROJECT AREA MAP

LOCATION INFORMATION

MH-ID
LOCATION
TWSHP, RNG, SCTN, Q-SCTN
MH-ID-XXX

THIS INFORMATION IS FOR INFORMATIONAL PURPOSES ONLY AND IS NOT TO BE USED FOR THE PROJECT. THE INFORMATION IS NOT TO BE USED FOR ANY OTHER PURPOSES. THE INFORMATION IS NOT TO BE USED FOR ANY OTHER PURPOSES. THE INFORMATION IS NOT TO BE USED FOR ANY OTHER PURPOSES.

PROJECT NAME: NAME 2 (IF LONG)
NAME 1

ORIGINAL DATE: XXXXXXXX

REVISED DATE: XXXXXXXX

DRAWN BY: XXX - COMPANY NAME

TOP VIEW NO: WORK #

SHEET NUMBER: 02 OF 03

AS-BUILT

SUBMITTAL DATE: XXXXXXXX

CONTRACTOR: COMPANY NAME

APPROVED DATE:

BY COP-ITS:

Figure 7

Splice Details

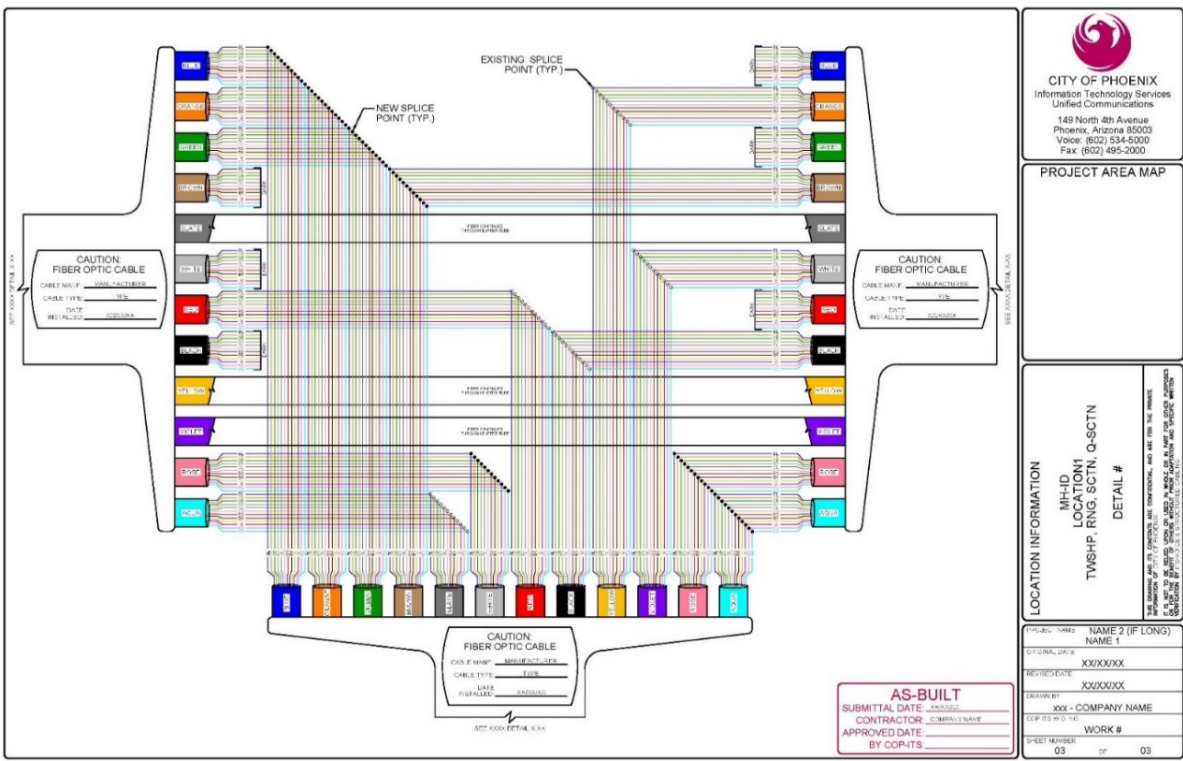

Figure 8

Domain: INF Architecture	Number: 200.215	Standard Title: Telecommunications Cabling Systems
------------------------------------	---------------------------	--

Placard

Mail

New

NAME PLATE DETAILS

- ① Plate height
- ② Plate width
- ③ Lettering height; Color is black
- ④ Plate material is plastic; Color is orange

 City of Phoenix	Building Address		
	Building Name and Department		
ITD - TELECOMMUNICATIONS	SIZE 8.5" x 11"	TSR NO. [Redacted]	DESCRIPTION TELECOM ROOM IDENTIFICATION DETAILS
251 W Washington St. Phoenix, AZ 85003	PAGE	TEMPLATE	FORM TELECOM ROOM PLACARD

Figure 9

Domain: INF Architecture	Number: 200.215	Standard Title: Telecommunications Cabling Systems
------------------------------------	---------------------------	--

House Fiber Cable Tag

House Fiber Cable Tag Example

House Fiber Cable Example in GIS

 City of Phoenix				
ITD - TELECOMMUNICATIONS	SIZE 8.5" x 11"	TSR NO.	DESCRIPTION HOUSE FIBER CABLE LABELING SCHEME	REV 10/12/04
251 W Washington St. Phoenix, AZ 85003	PAGE	EXAMPLE	FORM	HOUSE FIBER CABLE

Figure 10

Domain: INF Architecture	Number: 200.215	Standard Title: Telecommunications Cabling Systems
------------------------------------	---------------------------	--

Remote Fiber Cable Tag

Remote Fiber Cable Tag Example
Remote Building to Remote Building

Remote Fiber Cable Example in GIS

 City of Phoenix			
ITD - TELECOMMUNICATIONS	SIZE 9.5" x 11"	TSR NO.	DESCRIPTION REMOTE FIBER CABLE LABELING SCHEME
251 W Washington St. Phoenix, AZ 85003	PAGE EXAMPLE	FORM	REV 10/12/04
			REMOTE FIBER CABLE

Figure 11

Domain:
INF Architecture

Number:
200.215

Standard Title:
Telecommunications Cabling Systems

AutoCAD Drawing File

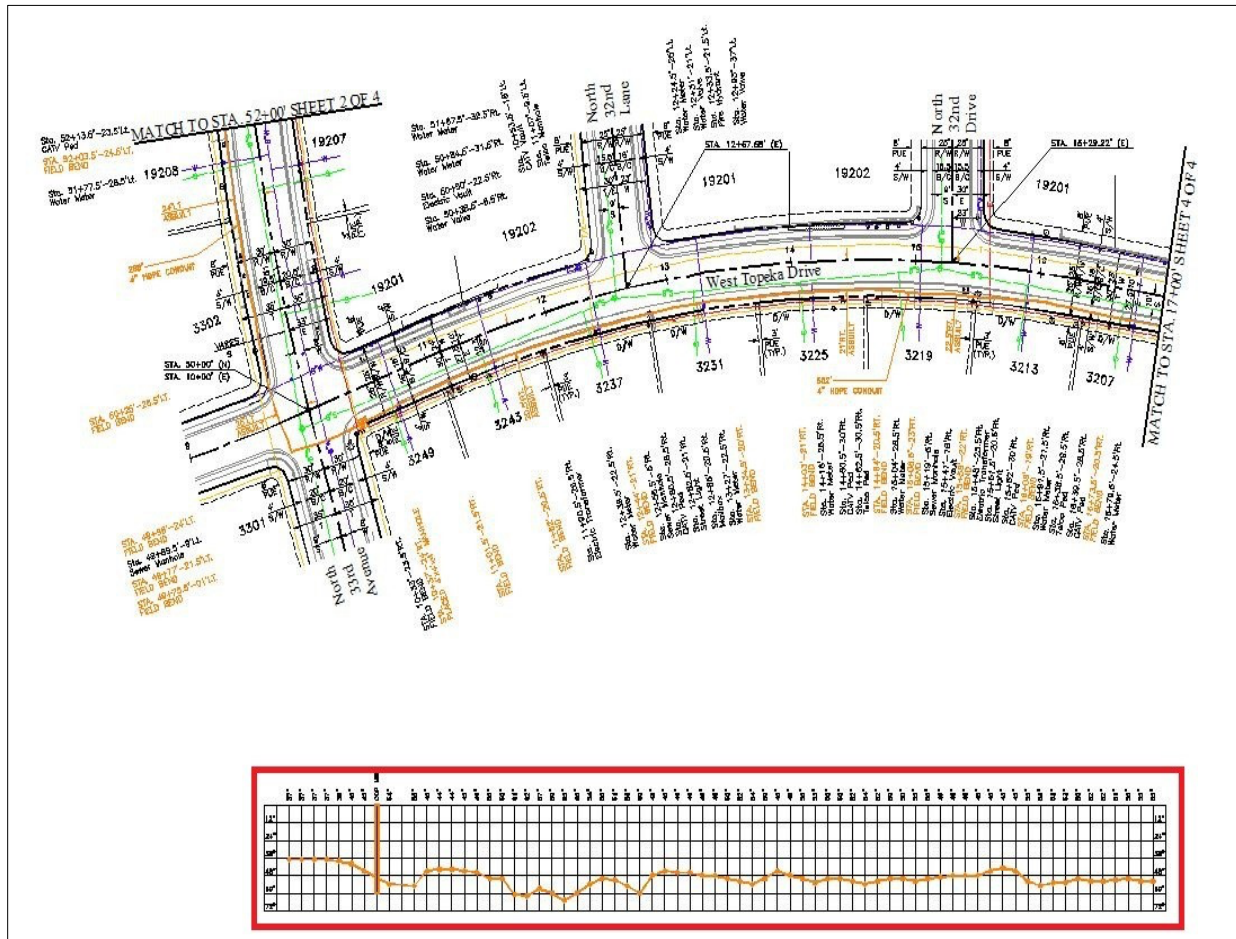

Figure 12