

PHX DVT GYR

CITY OF PHOENIX AVIATION DEPARTMENT

City of Phoenix Aviation Department Rules & Regulations

Number: R&R 02-06

Authority:

This Rule and Regulation is promulgated pursuant to City Code, Chapter 4 Article I, Sections 4-2, 4-6, 4-12, 4-16 and Article V, Sections 4-94, 4-95, 4-97, 4-99, 4-100, 4-102, 4-103, 4-104, 4-105, 4-106, 4-107, 4-109, 4-110, 4-116 and 4-117.

Rule and Regulation:

General Aviation Handbook

This handbook has been developed as an easy reference tool to provide the general aviation tenant with a summary of the Rules and Regulations regarding the use of facilities on City of Phoenix Airports.

The information contained in this publication is not meant to be all-inclusive but, rather, to provide answers to commonly asked questions and to supplement the Aviation Department Aircraft Storage Permit.

The final determination regarding the safety of any operation will be at the discretion of the Deputy Aviation Director – Business and Development, or designee, for Phoenix Sky Harbor International Airport, or Airport Manager, or designee for Phoenix Deer Valley or Phoenix Goodyear airports (hereinafter “Designee”), or Phoenix Fire Department for all City of Phoenix Airports.

Non-conformance with these Rules and Regulations is cause for revocation of a tenant’s aircraft storage permit.

I. STORAGE SPACE/VEHICLE PARKING

1. Subleasing

- a. Subleasing of aircraft storage space is prohibited.
- b. A ninety (90) day temporary storage of an aircraft other than the tenant’s may be permitted once a calendar year with the approval of the Designee.

2. Required Safety Precautions

- a. The v-shaped opening at the top of interior partitions of Hangars should not be obstructed.
- b. Fire extinguishers are provided by the City of Phoenix Aviation Department and must remain in the Hangar.

PHX DVT GYR

CITY OF PHOENIX AVIATION DEPARTMENT

City of Phoenix Aviation Department Rules & Regulations

- c. Smoking is strictly prohibited in the Hangar.
- d. "NO SMOKING" signs posted in the Hangar shall be visible and not blocked or obliterated.

3. Storage Space can be used for storage of:

- a. Aircraft authorized by your aircraft storage permit.
- b. Aviation related items.
- c. Motorized carts or bicycles for use as transportation on the Airport with written permission of the Designee.
- d. Up to three (3) spare aircraft tires.
- e. Two (2) tables.
- f. One (1) sofa.
- g. Four (4) chairs.
- h. Refrigerators as long as they are elevated 18 inches above the hangar floor, are not within the five foot hazardous area, and are **NOT** connected to any electrical outlet with an extension cord. Tenants are encouraged to use small capacity energy efficient refrigerators.
- i. Prefabricated metal shelves, workbenches and cabinets. Fire resistant materials are encouraged. **Do not attach any shelving to the hangar structure.**
- j. Two aircraft batteries. Pursuant to NFPA 410 4.2.13 "Battery chargers and their control equipment, tables, racks, trays, and wiring shall be located or operated as follows:

- (1) Not within any of the hazardous areas defined in 513.3

PHX DVT GYR

CITY OF PHOENIX AVIATION DEPARTMENT

City of Phoenix Aviation Department Rules & Regulations

(2) of NFPA 70" (same 18" and 5' around aircraft).

4. Storage Space may not be used for the storage of:

- a. Non-aviation related items.
- b. Motor homes, boats, clothing, files and furniture (except as outlined below).
- c. Appliances that are not functional.
- d. Propane Canisters

5. The prolonged storage of damaged/dismantled aircraft or aircraft that appear not to be airworthy in aircraft shades, tie downs or other unscreened areas of the airport shall not exceed thirty (30) calendar days after written notification from the Designee. The aircraft owner is required to correct such unsightly conditions as soon as possible to prevent degrading the airport appearance.

6. Storage of items at a t-shade or open tie-down space is prohibited unless approved by the Designee.

7. Removing interior panels or partitions or drilling in the Hangar floor in order to install any bench, winch or other piece of equipment is prohibited without the prior written approval of the Designee.

II. VEHICULAR PARKING

1. Parking in Storage Space

- a. Passenger vehicles may be stored in the hangar only while the aircraft is in use.
- b. Vehicles parked in a storage space shall be parked in a manner so as to be completely contained in the aircraft parking or storage space and not obstruct adjacent aircraft parking and storage space, or taxi

PHX DVT GYR

CITY OF PHOENIX AVIATION DEPARTMENT

City of Phoenix Aviation Department Rules & Regulations

lanes unless for the purpose of immediate and temporary loading, unloading, or staging of an aircraft.

2. **Long/Short Term Parking within the Airport parking fingers**
 - a. Short term parking - may not exceed three (3) days. Vehicles or trailers parked over three (3) days are deemed to be parked long term.
 - b. Long term parking – if parking exceeds three (3) days the tenant must obtain a permit from Airport Administration. Fees may apply.
 - c. Recreational vehicles and trailers (other than aircraft transport trailers) may be parked in Parking Fingers or Airport parking lots, but shall not be allowed to park long term.
 - d. **Vehicles found in violation of City Ordinance or regulations, including unregistered or inoperable vehicles are subject to tow at the owner's expense.**

III. MAINTENANCE/TOOLS

1. The only maintenance allowed in a hangar is the maintenance listed in 14 CFR Part 43 *except for* (a) Major repairs, items number xxviii and (b) Preventive maintenance items number 9 and 10. The repairs listed in (a) and (b) are prohibited in a hangar. All work shall be performed within the FAA established guidelines.
2. Maintenance in open tie downs and t-shades is prohibited.
3. **Hazardous operations that include any of the following are prohibited in a hangar: fuel transfer service, hot work, spray painting, paint stripping, or doping.**
4. Certain electrical appliances or tools are not suitable for use in some areas of the Hangar. In order to provide a

PHX DVT GYR

CITY OF PHOENIX AVIATION DEPARTMENT

City of Phoenix Aviation Department Rules & Regulations

reasonable degree of safety for persons and property from electrical hazards, please be aware of the following guidelines.

5. Certain areas of aircraft Hangars are classified as hazardous locations. Hazardous locations are areas where flammable or ignitable concentrations of volatile vapors or liquids might be present in the Hangar. Some of the contributing factors to the creation of hazardous locations are aircraft fuel and other fluids used in an aircraft and during routine maintenance. **The following diagram is included to assist in clarifying hazardous locations:**

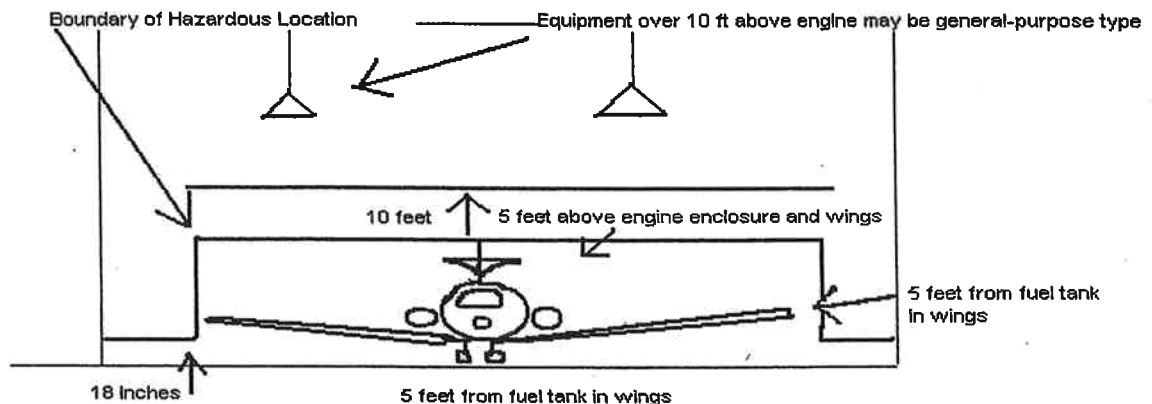

6. Electrical equipment approved for use in hazardous locations must be labeled or marked by the manufacturer with "SUITABLE FOR USE IN A CLASS 1, DIVISION 2 LOCATION." All other electrical appliances are prohibited to be used in the hazardous locations.
7. Electrical extension cords, for use with portable equipment only, must be listed and approved (i.e. Underwriters Laboratory (U/L) or Factory Mutual (FM)). **Outlet connectors or extension cords designated for indoor or household use may not be used.** All extension cords/power strips shall be of the heavy-duty type, three wire (two current carrying conductors and a grounding conductor) and **must be disconnected when the tenant is not in the hangar.**

PHX DVT GYR

CITY OF PHOENIX AVIATION DEPARTMENT

City of Phoenix Aviation Department Rules & Regulations

8. Open flames, flame-producing devices and other sources of ignition shall not be permitted in the hangars.
9. Limited touch-up painting or refinishing may be completed in a maintenance bay using aerosol spray cans. Approval may be granted for painting small parts in the hangar within specific guidelines developed with the Designee, the Fire Department, and the Environmental Programs Coordinator.

IV. AIRCRAFT MAINTENANCE PROVIDERS

1. A tenant may chose to use a private company for aircraft maintenance providing the company complies with Phoenix City Code, Chapter 4, Article I, Section 4-6. The tenant shall be responsible for all conduct on the Airport by a private company he/she has engaged. The private company must have an approved business permit as set forth in the Minimum Standards to allow them to conduct this commercial activity at the Airport.

V. FLAMMABLE/COMBUSTIBLE LIQUIDS

1. Classification of flammable/combustible liquids and flash points can be found on an *MSDS. The Aviation and Fire Departments have developed storage amounts for flammable and combustible liquids based upon a flash point of 100° F.
2. Flammable and combustible liquids must be in their original labeled containers and may not be stored in a Hangar in amounts that exceed the following:
 - a. **Flammable Liquids "Allowed" (excluding fluids contained in aircraft.** A total of eight (8) gallons of flammable liquids with a flash point below 100° F. Products labeled as "spontaneously combustible" will be counted toward the eight (8) gallon flammable limit.

Examples: Acetone, MEK, most aerosol sprays, black wing walk, gasket adhesive.
 - b. **Combustible Liquids**

PHX DVT GYR

CITY OF PHOENIX AVIATION DEPARTMENT

City of Phoenix Aviation Department Rules & Regulations

II - 8 gallons

(Liquids having a closed cup flash point at or above 100° F and below 140° F.)

IIIA - 23 gallons

(Liquids having a closed cup flash point at or above 140° F and below 200° F.)

IIIB - 900 gallons **

(Liquids having a closed cup flash point at or above 200°F.)

***Examples: Hydraulic fluid, oil (lubricating, motor and turbine), mineral spirits, torque seal.*

3. **WARNING:** Although the chemical contents of an aerosol spray may have a flash point above 100° F, manufacturers commonly incorporate propane or isobutane as a propellant, which is extremely flammable under pressure. Therefore, any container utilizing a propellant of this type will be counted toward the eight-gallon flammable limit.
4. If a tenant (or the inspector) is not sure what class liquid they have, they will need to produce an MSDS to supply the required information.
5. Oily rags and other oily waste material shall be stored in properly marked metal containers with tight fitting lids only.
6. Tenants may be requested to remove or have cleaned any furniture or work surface that appears to be impregnated or soaked with combustible or flammable liquids.
7. Oxygen nitrogen or any compressed gas in a cylinder or portable tank must be secured to a fixed location or a portable cart designed for the cylinder(s) or tank(s). Compressed gas cylinders or tanks must have pressure relief devices installed and maintained. Cylinders or tanks not in use shall have a transportation safety cap installed.

PHX DVT GYR



CITY OF PHOENIX AVIATION DEPARTMENT

City of Phoenix Aviation Department Rules & Regulations

8. Oxygen must be kept at least twenty (20) feet from any flammable or combustible liquid storage.

VI. HANGAR ELECTRICAL SYSTEM

1. Aircraft hangars are designed and classified for storage or limited servicing of aircraft as described in the Rule and Regulation.
2. Certain electric hangar doors are equipped with separate "up" and "down" switches, or buttons. These buttons are designed so that the operator must be present while the door button is activated. Blocking these buttons in either position with any foreign objects so that the operator can remove his hands from the switch assembly is prohibited. **DO NOT BLOCK THE DOOR BUTTONS!**
3. The electrical system serving the hangar was not designed for the additional electrical loads that appliances require. Should a circuit breaker to trip or if a tenant experiences any difficulty, they should contact Airport Operations for assistance. **A tenant shall not attempt to reset a tripped circuit breaker.**

VII. BUILDING MODIFICATIONS

1. A tenant must receive prior written approval from the Designee before doing any modifications or additions to the Hangar. The Designee will advise if a building permit is required. If a building permit is required for structural/electrical modifications and is approved by the Designee the process to obtain a permit is the following:
 - a. If a building permit is required, the Designee will provide a letter to the tenant authorizing City of Phoenix Annual Facilities Program (AFP) to issue a permit for scope of work. Receipt of approval letter from the Designee **does not relieve tenants** from their responsibility to obtain a building permit and get a "green tag."
 - b. Tenant is responsible for providing sufficient information to AFP reviewer to approve scope of work, including but not limited to, providing a drawing of the proposed work and a

PHX DVT GYR

CITY OF PHOENIX AVIATION DEPARTMENT

City of Phoenix Aviation Department Rules & Regulations

- copy of the approval letter from the Designee. The tenant is responsible for obtaining a permit.
- c. Upon approval, only a State of Arizona licensed contractor may conduct the work.
 - d. After a permit is issued the tenant is responsible for coordinating access for the contractor to the hangar following the Rules and Regulations.
 - e. The tenant is responsible for obtaining inspections by the AFP and providing the Designee with the "green tag" or certificate of completion from the inspector which will be maintained in the hangar file.

***NOTE:** Procedures for Phoenix Goodyear Airport may vary. Please check with the Phoenix Goodyear Airport Manager.*

IGNITION SOURCES

VIII. ENVIRONMENTAL DISPOSAL

1. Combustible or flammable liquids, including pre-flight fuel samples, antifreeze and petroleum waste products may not be discharged or released into storm drains, wastewater (sanitary) systems or onto the ground or apron.
2. Soaps, chemicals, fuels, trash, etc., shall be stored in such a manner that rainfall will not wash residues to the storm drain system. **Discharges to storm drain systems or onto the ground or apron may require the responsible party to remediate the discharge to State and/or Federal clean-up standards.**
3. **All spills or releases should be reported immediately to the Airport Operations.**
4. **All conduct must comply with SWPPP.**

PHX DVT GYR

CITY OF PHOENIX AVIATION DEPARTMENT

City of Phoenix Aviation Department Rules & Regulations

IX. WASH RACKS/MAINTENANCE BAYS

- 1. Wash racks and maintenance bays are available on a first come first serve basis.**
2. All washing of aircraft is restricted to the designated wash racks.
3. Tenants must not leave the aircraft unattended in the wash rack and must promptly remove the aircraft from the wash rack upon completion.
4. Washing of automobiles is prohibited on the airport.
5. Do not wash aircraft parts or do paint stripping with any hazardous products such as Methylene Chloride or Methyl Ethyl Ketone (MEK) in the wash racks or maintenance bay.
- 6. Discharging wash water into the City storm water system is strictly prohibited.**
- 7. The dumping of any excess fluids such as waste oil, solvents or other cleaning agents is expressly prohibited.**
8. Maintenance Bays may be used up to two (2) consecutive days without charge to the tenant. If additional time is required, approval must be obtained from the Designee and appropriate fees may apply.

X. AIRCRAFT WASHING PROVIDER

1. A tenant may choose to use a private company for aircraft cleaning or washing providing the company complies with Phoenix City Code, Chapter 4, Article I, Section 4-6. The tenant shall be responsible for all conduct on the Airport by a private party he/she has engaged. The private company must have an approved business permit as set forth in the Minimum Standards to allow them to conduct this commercial activity at the Airport.

XI. WASTE SITES

1. Disposal of aviation liquid waste must be conducted in accordance with the labels on the City provided containers only.

PHX DVT GYR

CITY OF PHOENIX AVIATION DEPARTMENT

City of Phoenix Aviation Department Rules & Regulations

2. Waste disposal drums are available for non-commercial general aviation tenants. Commercial operators are prohibited from using the containers for disposal of their wastes.
3. Trash dumpsters are at various locations throughout the Airport.
4. Containment areas are available for used aircraft tires and batteries.
5. Used tires, batteries and hazardous liquids **may not** be placed in trash receptacles.

Please contact the Airport Operations if you have any questions regarding the disposal of any item.

XII. AIRCRAFT FUELING

1. Aviation fuel may not be dispensed into or removed from the fuel system of an aircraft within the hangar.
2. **For fueling or defueling operations, the aircraft must be a minimum of twenty-five (25) feet outside of the Hangar in accordance with NFPA standards for fueling operations. Twenty-five feet will be measured from the front of the hangar to the aircraft fuel filler cap.**
3. Fueling and defueling must be done in accordance with the Aviation Department's Fueling Regulations.

XIII. AIRCRAFT FUEL SAMPLES

1. Disposal of pre-flight fuel samples on the apron or ground is prohibited. This practice has been deemed unlawful by the Arizona Department of Environmental Quality (ADEQ).

The following are several options for the proper disposal of fuel samples:

- a. The use of fire rated containers in Hangars (up to the six (6) gallon maximum for flammables) for temporary

PHX DVT GYR

CITY OF PHOENIX AVIATION DEPARTMENT

City of Phoenix Aviation Department Rules & Regulations

storage prior to disposal.

b. The use of gasoline separator jars or a similar product.

Note: The City of Phoenix Aviation Department makes no representation, expressed or implied, regarding the use, safety or availability of these products.

The foregoing Rules and Regulations are hereby adopted and promulgated this 7 day of September, 2007.

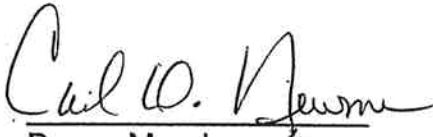

Danny Murphy *fa*
Aviation Director



Nancy Kesteloot *ck*
Assistant Chief Counsel